

INSTALLATION NOTES:

- ONE (1) INSTALLATION ANCHOR IS REQUIRED AT EACH ANCHOR LOCATION SHOWN.
- THE NUMBER OF INSTALLATION ANCHORS DEPICTED IS THE MINIMUM NUMBER OF ANCHORS TO BE USED FOR PRODUCT INSTALLATION.
- INSTALL INDIVIDUAL INSTALLATION ANCHORS WITHIN A TOLERANCE OF ±1/16 INCH OF THE DEPICTED LOCATION IN THE ANCHOR LAYOUT DETAIL (I.E., WITHOUT CONSIDERATION OF TOLERANCES). TOLERANCES ARE NOT CUMULATIVE FROM ONE INSTALLATION ANCHOR TO THE NEXT.
- SHIM AS REQUIRED AT EACH INSTALLATION ANCHOR WITH LOAD BEARING SHIM(S). MAXIMUM ALLOWABLE SHIM STACK TO BE 1/4 INCH. SHIM WHERE SPACE OF 1/16 INCH OR GREATER OCCURS. SHIM(S) SHALL BE CONSTRUCTED OF HIGH DENSITY PLASTIC OR BETTER.
- FOR INSTALLATION INTO 2X WOOD FRAMING USE #12 WOOD SCREWS OF SUFFICIENT LENGTH TO ACHIEVE 1 1/2 INCH MINIMUM EMBEDMENT INTO WOOD SUBSTRATE WITH MINIMUM 1 INCH EDGE DISTANCE.
- FOR INSTALLATION THROUGH 1X BUCK TO CONCRETE/MASONRY, OR DIRECTLY INTO CONCRETE/MASONRY, USE 3/16 INCH DIAMETER ITW TAPCONS OR ELCO ULTRACONS OF SUFFICIENT LENGTH TO ACHIEVE 1 3/4 INCH MINIMUM EMBEDMENT WITH MINIMUM 2 1/2 INCH EDGE DISTANCE.
- ALTERNATIVELY, ANCHORS FOR INSTALLATION THROUGH 1X BUCK TO CONCRETE/MASONRY, OR DIRECTLY INTO CONCRETE/MASONRY, MAY BE 7.5 MM (5/16 INCH NOMINAL) TIMCO T30 TORX CONCRETE SCREWS, OF SUFFICIENT LENGTH TO ACHIEVE 1 3/4 INCH MINIMUM EMBEDMENT WITH A MINIMUM 2 1/2 INCH EDGE DISTANCE.
- FOR INSTALLATION INTO 33 KSI STEEL STUD USE 3/16 TEK SCREWS OF SUFFICIENT LENGTH TO ACHIEVE THREE (3) THREADS MINIMUM PENETRATION BEYOND THE STEEL STRUCTURE.
- MINIMUM EMBEDMENT AND EDGE DISTANCE EXCLUDE WALL FINISHES, INCLUDING BUT NOT LIMITED TO STUCCO, FOAM, BRICK VENEER, AND SIDING.
- INSTALLATION ANCHORS AND ASSOCIATED HARDWARE MUST BE MADE OF CORROSION RESISTANT MATERIAL OR HAVE A CORROSION RESISTANT COATING.
- FOR GROUT FILLED OR HOLLOW BLOCK, DO NOT INSTALL INSTALLATION ANCHORS INTO MORTAR JOINTS. EDGE DISTANCE IS MEASURED FROM FREE EDGE OF BLOCK OR EDGE OF MORTAR JOINT INTO FACE SHELL OF BLOCK.
- INSTALLATION ANCHORS SHALL BE INSTALLED IN ACCORDANCE WITH ANCHOR MANUFACTURER'S INSTALLATION INSTRUCTIONS, AND ANCHORS SHALL NOT BE USED IN SUBSTRATES WITH STRENGTHS LESS THAN THE MINIMUM STRENGTH SPECIFIED IN THIS APPROVAL.
- INSTALLATION ANCHOR CAPACITIES FOR PRODUCTS HEREIN ARE BASED ON SUBSTRATE MATERIALS WITH THE FOLLOWING PROPERTIES:
  - WOOD - MINIMUM SPECIFIC GRAVITY OF 0.55.
  - CONCRETE -MINIMUM COMPRESSIVE STRENGTH OF 3000 PSI.
  - GROUT-FILLED CMU- UNIT STRENGTH CONFORMS TO ASTM C-90 WITH MINIMUM COMPRESSIVE STRENGTH OF 1924 PSI AND GROUT CONFORMS TO ASTM C 476, MINIMUM GROUT COMPRESSIVE STRENGTH OF 2000 PSI.
  - HOLLOW BLOCK CMU - UNIT STRENGTH CONFORMS TO ASTM C-90 WITH MINIMUM COMPRESSIVE STRENGTH OF 1924 PSI.
  - STEEL - MINIMUM YIELD STRENGTH OF 33 KSI. MINIMUM WALL THICKNESS OF 43 MIL (0.0428" or 18 GAUGE). MIN. 1/2" EDGE DISTANCE.

# THE FOLDING SLIDING DOOR COMPANY

## FSD WORKS

### HD82-70 MM FOLDING OUTFOLDING DOOR SYSTEM

GENERAL NOTES:

- THE PRODUCT SHOWN HEREIN IS DESIGNED AND MANUFACTURED TO COMPLY WITH THE CURRENT EDITION OF THE FLORIDA BUILDING CODE (FBC), EXCLUDING HVHZ AND HAS BEEN EVALUATED ACCORDING TO THE FOLLOWING:
  - TAS 202-94
- ADEQUACY OF THE EXISTING STRUCTURAL CONCRETE/MASONRY, 2X WOOD & STEEL FRAMING AS A MAIN WIND FORCE RESISTING SYSTEM CAPABLE OF WITHSTANDING AND TRANSFERRING APPLIED PRODUCT LOADS TO THE FOUNDATION IS THE RESPONSIBILITY OF THE ENGINEER OR ARCHITECT OF RECORD FOR THE PROJECT OF INSTALLATION.
- 1X AND 2X BUCKS (WHEN USED) SHALL BE DESIGNED AND ANCHORED TO PROPERLY TRANSFER ALL LOADS TO THE STRUCTURE. BUCK DESIGN AND INSTALLATION IS THE RESPONSIBILITY OF THE ENGINEER OR ARCHITECT OF RECORD FOR THE PROJECT OF INSTALLATION.
- THE INSTALLATION DETAILS DESCRIBED HEREIN ARE GENERIC AND MAY NOT REFLECT ACTUAL CONDITIONS FOR A SPECIFIC SITE. IF SITE CONDITIONS CAUSE INSTALLATION TO DEVIATE FROM THE REQUIREMENTS DETAILED HEREIN, A LICENSED ENGINEER OR ARCHITECT SHALL PREPARE SITE SPECIFIC DOCUMENTS FOR USE WITH THIS DOCUMENT. FOR NON-HVHZ AREA, INSTALLATION TO BE REVIEWED BY AHJ (AUTHORITY HAVING JURISDICTION).
- APPROVED IMPACT PROTECTIVE SYSTEM **IS REQUIRED** ON THIS PRODUCT IN AREAS REQUIRING IMPACT RESISTANCE.
- DOOR FRAME MATERIAL: ALUMINUM 6063-T5
- GLASS MEETS THE REQUIREMENTS OF ASTM E 1300 GLASS CHARTS. SEE SHEET 7 FOR GLAZING DETAILS.
- IN ACCORDANCE WITH THE FBC, DISSIMILAR METALS INCLUDING FASTENERS THAT MAY COME INTO CONTACT WITH ALUMINUM UNIT FRAMING SHALL BE PROTECTED.
- FOR INSTALLATION OF RECESSED THRESHOLD 2X8 WOOD BUCK OR CONCRETE MUST BE RECESSED AND/OR ROUTED TO ACCOMMODATE THESE COMPONENTS PRIOR TO INSTALLATION. SEE SHEET 12 FOR TYPICAL DETAILS.
- GLAZING GASKETS SHALL MEET THE REQUIREMENTS OF THE FBC.

TABLE OF CONTENTS		
SHEET	REVISION	SHEET DESCRIPTION
1	B	INSTALLATION & GENERAL NOTES
2	B	ELEVATION & ANCHOR LAYOUT (1)
3	B	ELEVATION & ANCHOR LAYOUT (2)
4	B	ELEVATION & ANCHOR LAYOUT (3)
5	B	VERTICAL SECTIONS
6	B	HORIZONTAL SECTIONS
7	B	HORIZONTAL SECTIONS & GLAZING DETAILS
8	B	DESIGN PRESSURE TABLE
9	B	HARDWARE REQUIREMENTS & CONFIGURATIONS
10	B	COMPONENTS & BILL OF MATERIALS (1)
11	B	COMPONENTS & BILL OF MATERIALS (2)
12	B	THRESHOLD PREPARATION DETAILS

MISSILE IMPACT RATING	DESIGN PRESSURE
NOT IMPACT RATED	SEE SHEET 8 FOR DESIGN PRESSURES



THE FOLDING SLIDING DOOR COMPANY FSD WORKS  
HOPBINE AVE., WEST BOWLING  
BRADFORD, WEST YORKSHIRE, BD5 8ER, UK  
PH: (786) 275-5068

TITLE: HD82-70 MM FOLDING OUTFOLDING DOOR SYSTEM  
INSTALLATION & GENERAL NOTES

PREPARED BY: BUILDING DROPS, INC.  
398 E. DANIA BEACH BLVD., STE. 338  
DANIA BEACH, FL 33004  
PH: (954)399-8478  
FAX: (954)744-4738  
WEB: www.buildingdrops.com



REMARKS	BY	DATE
5TH. ED. FBC UPDATE	SM	04.30.15
NAME & ADDRESS UPDATE	LL	07.02.19

THE INSTALLATION DETAILS DESCRIBED HEREIN ARE GENERIC AND MAY NOT REFLECT ACTUAL CONDITIONS FOR A SPECIFIC SITE. IF SITE CONDITIONS CAUSE INSTALLATION TO DEVIATE FROM THE REQUIREMENTS DETAILED HEREIN, A LICENSED ENGINEER OR ARCHITECT SHALL PREPARE SITE SPECIFIC DOCUMENTS FOR USE WITH THIS DOCUMENT.

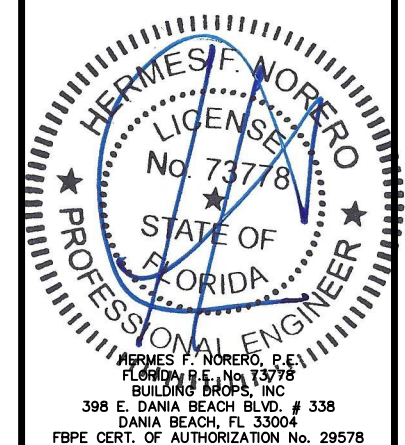

FL #: **FL16291**  
DATE: **04.11.2013**  
DWG. BY: **MTJ** | CHK. BY: **HFN**  
SCALE: **NTS**  
DWG. #: **FSD004**  
SHEET: **1**  
OF 12

8/16/2019 6:00 PM

s:\projects\the folding sliding door company\fb-19-0632 - fbc submittal - name change - fl16291 aluminum folding door system\dwgs\fsd04.dwg

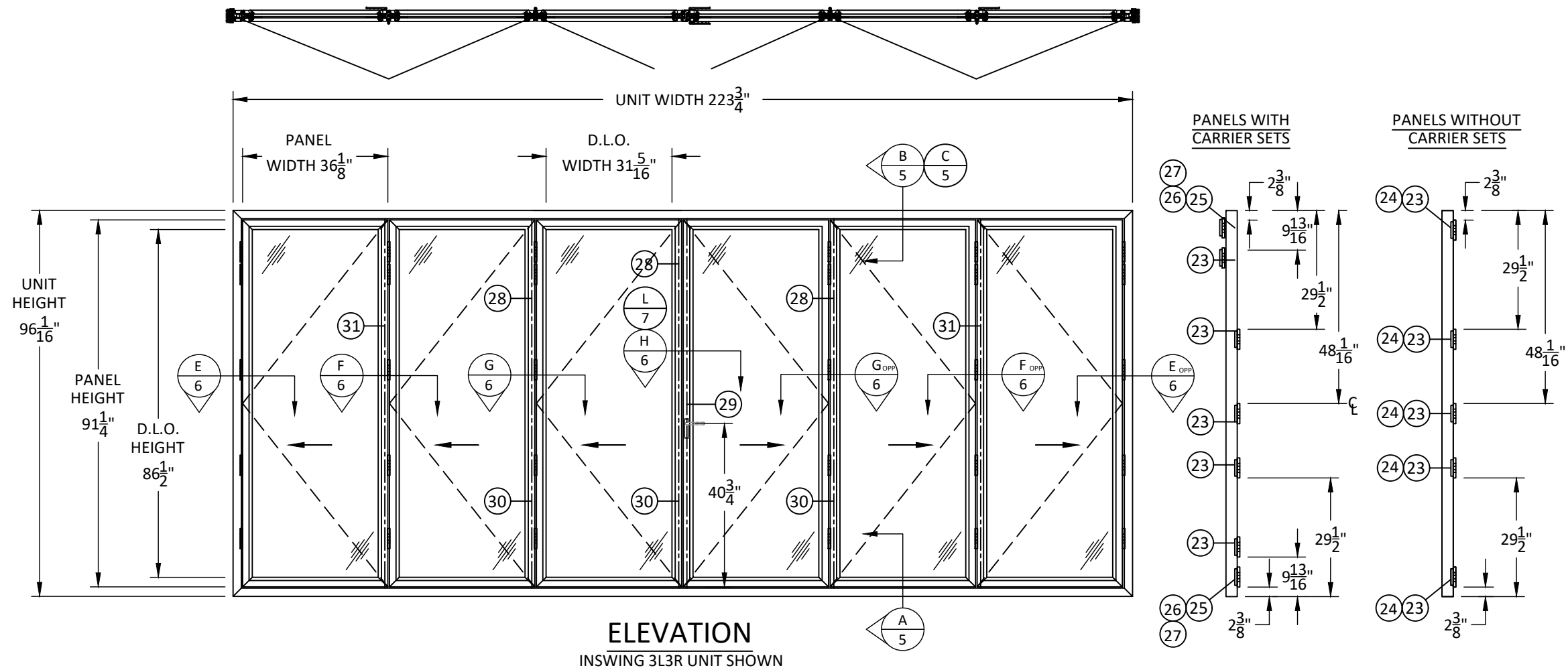

**ELEVATION**  
INSWING 3L3R UNIT SHOWN

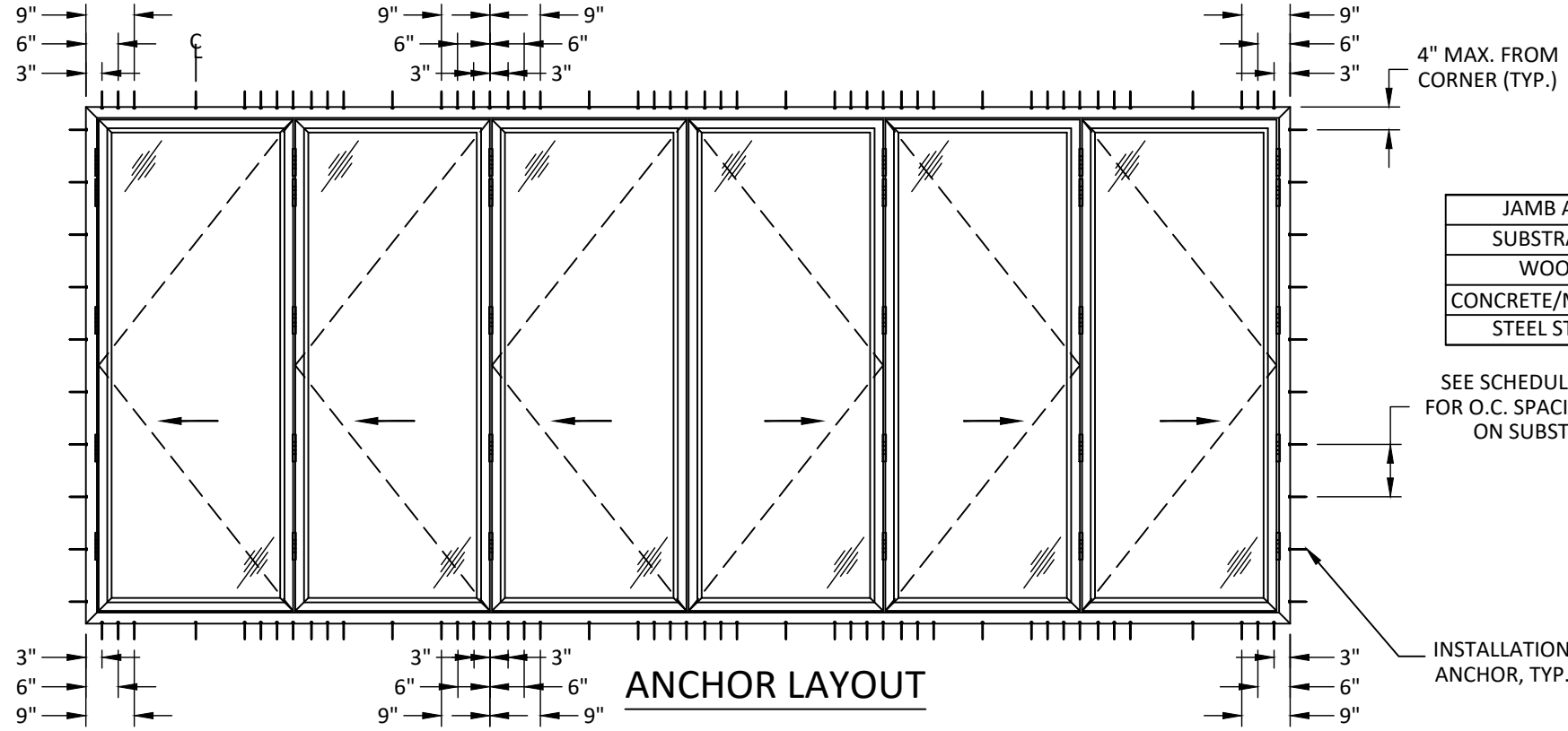

**ANCHOR LAYOUT**

**NOTE:**

1. AT JAMBS ONE (1) ADDITIONAL ANCHOR REQUIRED THROUGH EACH HINGE.
2. TESTED SIZE SHOWN. SEE SHEET 8 FOR OTHER QUALIFIED CONFIGURATIONS.
3. UNLIMITED FRAME WIDTH IS QUALIFIED SUCH THAT THE MAXIMUM PANEL SIZE, AS SHOWN HEREIN IS NOT EXCEEDED.



THE FOLDING SLIDING DOOR COMPANY FSD WORKS  
HOPBINE AVE., WEST BOWLING  
BRADFORD, WEST YORKSHIRE, BD5 8ER, UK  
PH: (786) 275-5068

TITLE: HD82-70 MM FOLDING OUTFOLDING DOOR SYSTEM ELEVATION & ANCHOR LAYOUT (1)

PREPARED BY: BUILDING DROPS, INC.  
398 E. DANIA BEACH BLVD., STE. 338  
DANIA BEACH, FL 33004  
PH: (954)399-8478  
FAX: (954)744-4738  
WEB: www.buildingdrops.com

REMARKS	BY	DATE
5TH. ED. FBC UPDATE	SM	04.30.15
NAME & ADDRESS UPDATE	LL	07.02.19

THE INSTALLATION DETAILS DESCRIBED HEREIN ARE GENERIC AND MAY NOT REFLECT ACTUAL CONDITIONS FOR A SPECIFIC SITE. IF SITE CONDITIONS CAUSE INSTALLATION TO DEVIATE FROM THE REQUIREMENTS DETAILED HEREIN, A LICENSED ENGINEER OR ARCHITECT SHALL PREPARE SITE SPECIFIC DOCUMENTS FOR USE WITH THIS DOCUMENT.

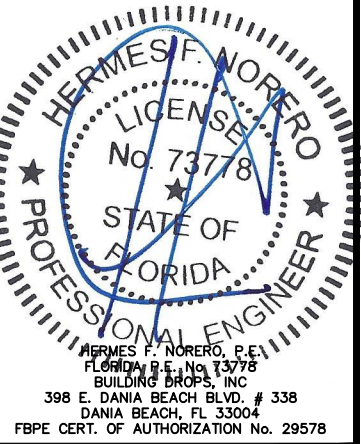

FL #:  
**FL16291**

DATE: **04.11.2013**

DWG. BY: **MTJ** | CHK. BY: **HFN**

SCALE: **NTS**

DWG. #: **FSD004**

SHEET:  
**2**  
OF 12

8/16/2019 6:00 PM

s:\projects\the folding sliding door company\fb-19-0632 - fbc submittal - name change - fl16291 aluminum folding door system\dwgs\sed04.dwg

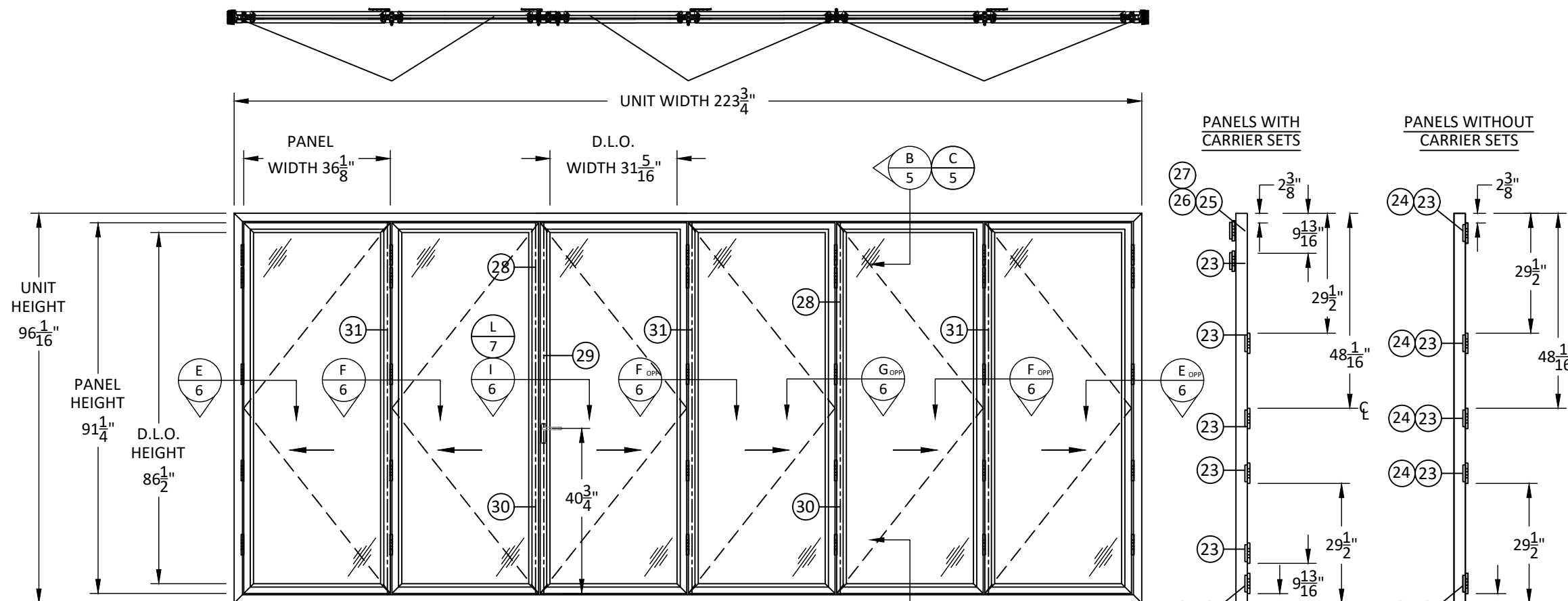

**ELEVATION**  
INSWING 2L4R UNIT SHOWN

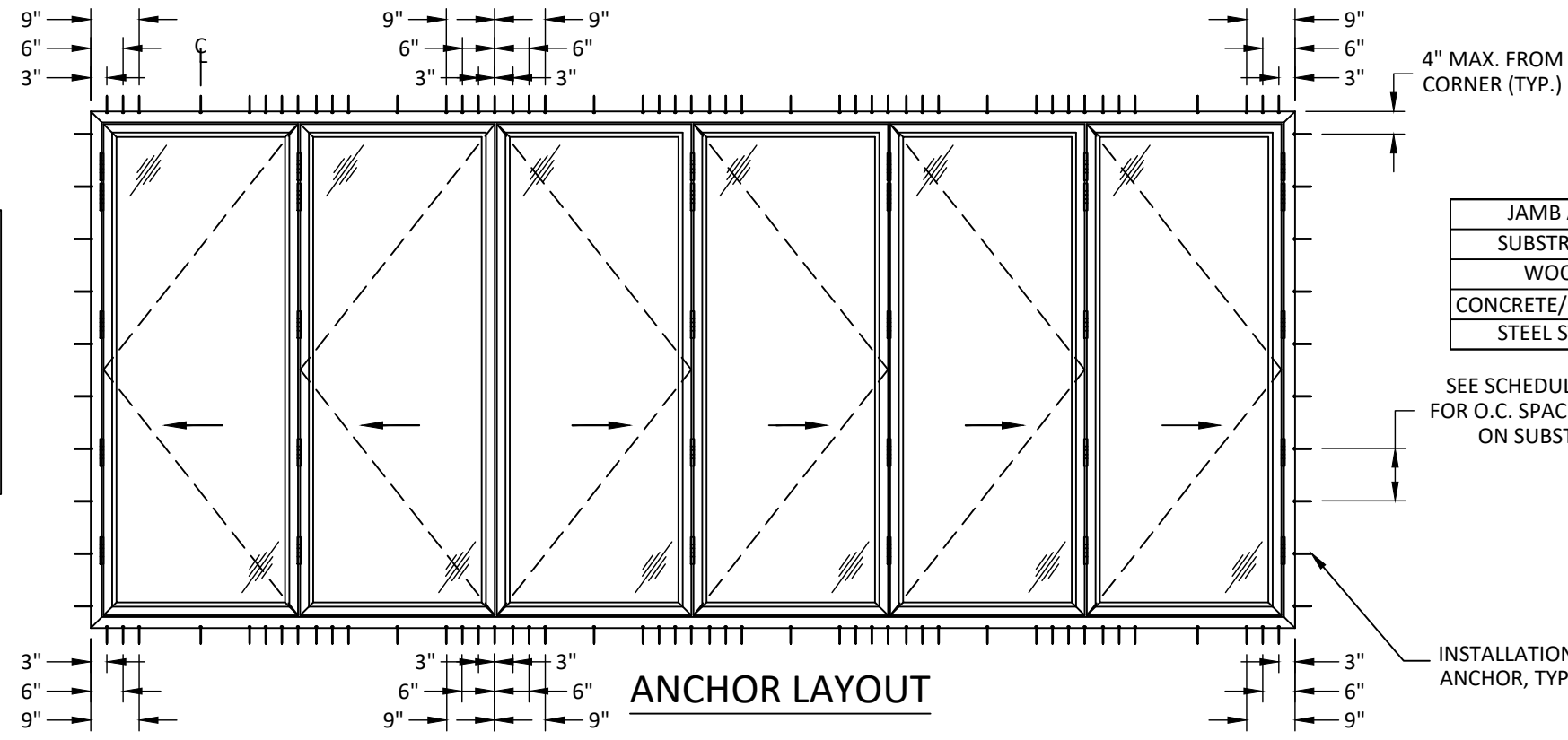

**NOTE:**

1. AT JAMBS ONE (1) ADDITIONAL ANCHOR REQUIRED THROUGH EACH HINGE.
2. TESTED SIZE SHOWN. SEE SHEET 8 FOR OTHER QUALIFIED CONFIGURATIONS.
3. UNLIMITED FRAME WIDTH IS QUALIFIED SUCH THAT THE MAXIMUM PANEL SIZE, AS SHOWN HEREIN IS NOT EXCEEDED.

JAMB ANCHOR SCHEDULE	
SUBSTRATE	O.C. SPACING
WOOD	8 7/8"
CONCRETE/MASONRY	8"
STEEL STUD	5 7/8"

SEE SCHEDULE ABOVE FOR O.C. SPACING BASED ON SUBSTRATE



THE FOLDING SLIDING DOOR COMPANY FSD WORKS  
HOPBINE AVE., WEST BOWLING BRADFORD, WEST YORKSHIRE, BD5 8ER, UK  
PH: (786) 275-5068

TITLE: HD82-70 MM FOLDING OUTSLIDING DOOR SYSTEM ELEVATION & ANCHOR LAYOUT (2)

PREPARED BY: BUILDING DROPS, INC.  
398 E. DANIA BEACH BLVD., STE. 338 DANIA BEACH, FL 33004  
PH: (954)399-8478 FAX: (954)744-4738  
WEB: www.buildingdrops.com

REMARKS	BY	DATE
5TH. ED. FBC UPDATE	SM	04.30.15
NAME & ADDRESS UPDATE	LL	07.02.19

THE INSTALLATION DETAILS DESCRIBED HEREIN ARE GENERIC AND MAY NOT REFLECT ACTUAL CONDITIONS FOR A SPECIFIC SITE. IF SITE CONDITIONS CAUSE INSTALLATION TO DEVIATE FROM THE REQUIREMENTS DETAILED HEREIN, A LICENSED ENGINEER OR ARCHITECT SHALL PREPARE SITE SPECIFIC DOCUMENTS FOR USE WITH THIS DOCUMENT.

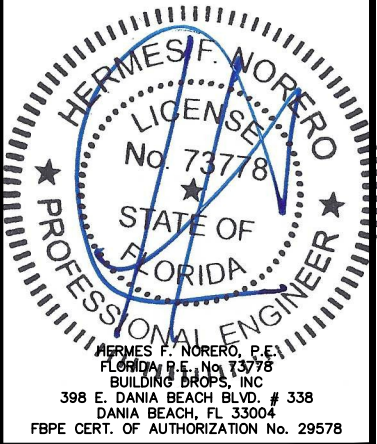

FL #: **FL16291**

DATE: **04.11.2013**

DWG. BY: **MTJ** | CHK. BY: **HFN**

SCALE: **NTS**

DWG. #: **FSD004**

SHEET:



8/16/2019 6:00 PM

s:\projects\the folding sliding door company\fb-19-0632 - fbc submittal - name change - fl16291 aluminum folding door system\dwgs\fsd04.dwg

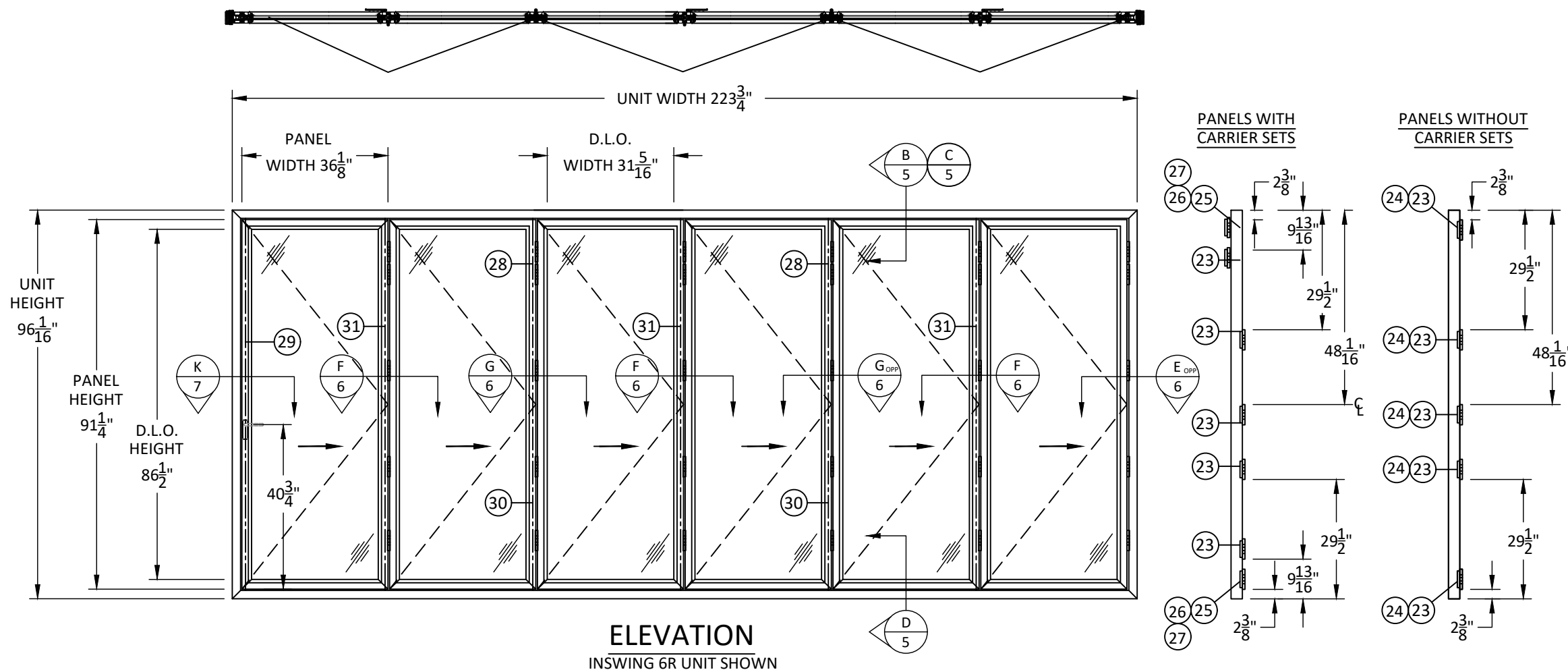

**ELEVATION**  
INSWING 6R UNIT SHOWN

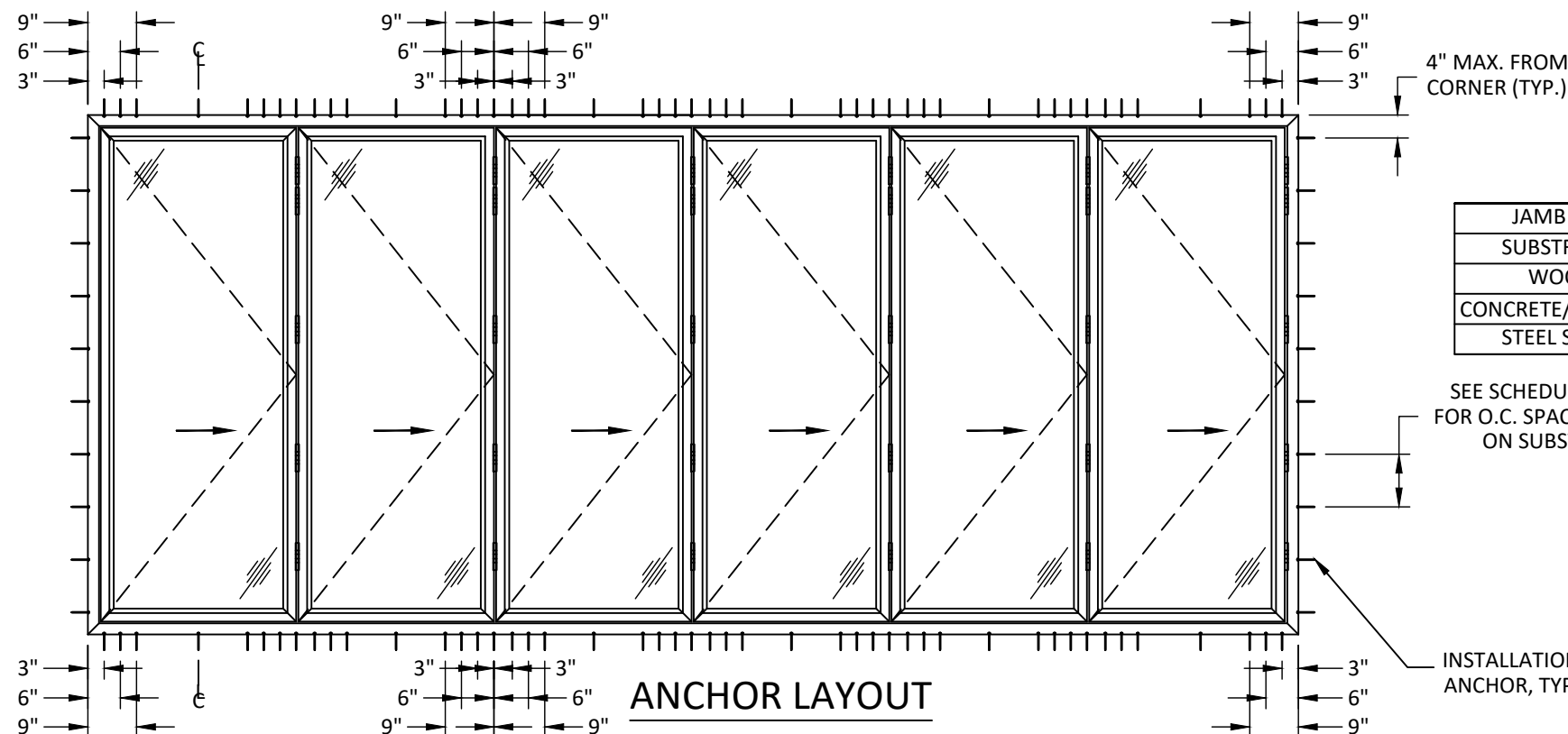

**ANCHOR LAYOUT**

**NOTE:**

1. AT JAMBS ONE (1) ADDITIONAL ANCHOR REQUIRED THROUGH EACH HINGE.
2. TESTED SIZE SHOWN. SEE SHEET 8 FOR OTHER QUALIFIED CONFIGURATIONS.
3. UNLIMITED FRAME WIDTH IS QUALIFIED SUCH THAT THE MAXIMUM PANEL SIZE, AS SHOWN HEREIN IS NOT EXCEEDED.

JAMB ANCHOR SCHEDULE	
SUBSTRATE	O.C. SPACING
WOOD	8 7/8"
CONCRETE/MASONRY	8"
STEEL STUD	5 7/8"

SEE SCHEDULE ABOVE FOR O.C. SPACING BASED ON SUBSTRATE

INSTALLATION ANCHOR, TYP.



THE FOLDING SLIDING DOOR COMPANY FSD WORKS  
HOPBINE AVE., WEST BOWLING BRADFORD, WEST YORKSHIRE, BD5 8ER, UK  
PH: (786) 275-5068

TITLE:  
HD82-70 MM FOLDING OUTFOLDING DOOR SYSTEM ELEVATION & ANCHOR LAYOUT (3)

PREPARED BY:  
**BUILDING DROPS, INC.**  
398 E. DANIA BEACH BLVD., STE. 338  
DANIA BEACH, FL 33004  
PH: (954)399-8478  
FAX: (954)744-4738  
WEB: www.buildingdrops.com

REMARKS	BY	DATE
5TH. ED. FBC UPDATE	SM	04.30.15
NAME & ADDRESS UPDATE	LL	07.02.19

THE INSTALLATION DETAILS DESCRIBED HEREIN ARE GENERIC AND MAY NOT REFLECT ACTUAL CONDITIONS FOR A SPECIFIC SITE. IF SITE CONDITIONS CAUSE INSTALLATION TO DEVIATE FROM THE REQUIREMENTS DETAILED HEREIN, A LICENSED ENGINEER OR ARCHITECT SHALL PREPARE SITE SPECIFIC DOCUMENTS FOR USE WITH THIS DOCUMENT.

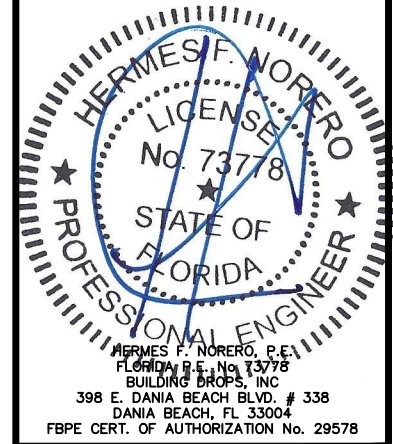

FL #:  
**FL16291**

DATE: **04.11.2013**

DWG. BY: **MTJ** | CHK. BY: **HFN**

SCALE: **NTS**

DWG. #: **FSD004**

SHEET:

8/16/2019 6:00 PM

s:\projects\the folding sliding door company\fb-19-0632 - fbc submittal - name change - fl16291 aluminum folding door system\dwg\fsd004.dwg

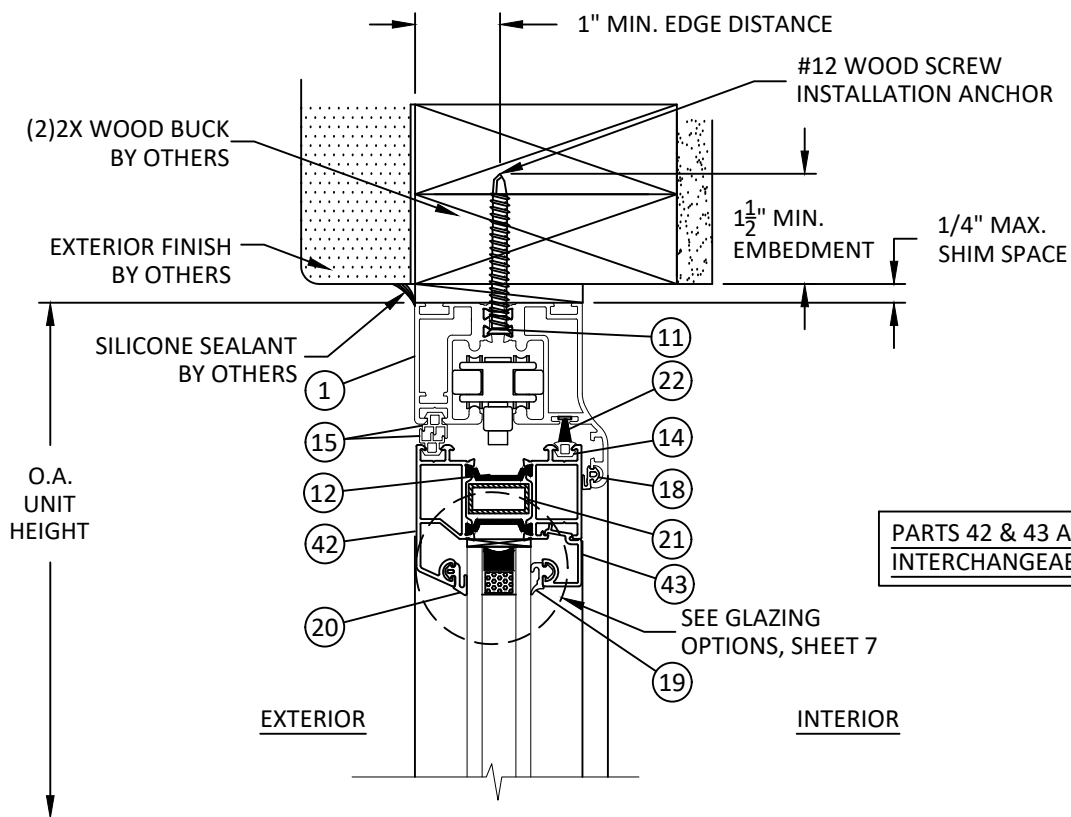

**B**  
5  
**VERTICAL SECTION**  
HEAD - 2X WOOD BUCK

MAX UNIT HEIGHT  
96-1/16"

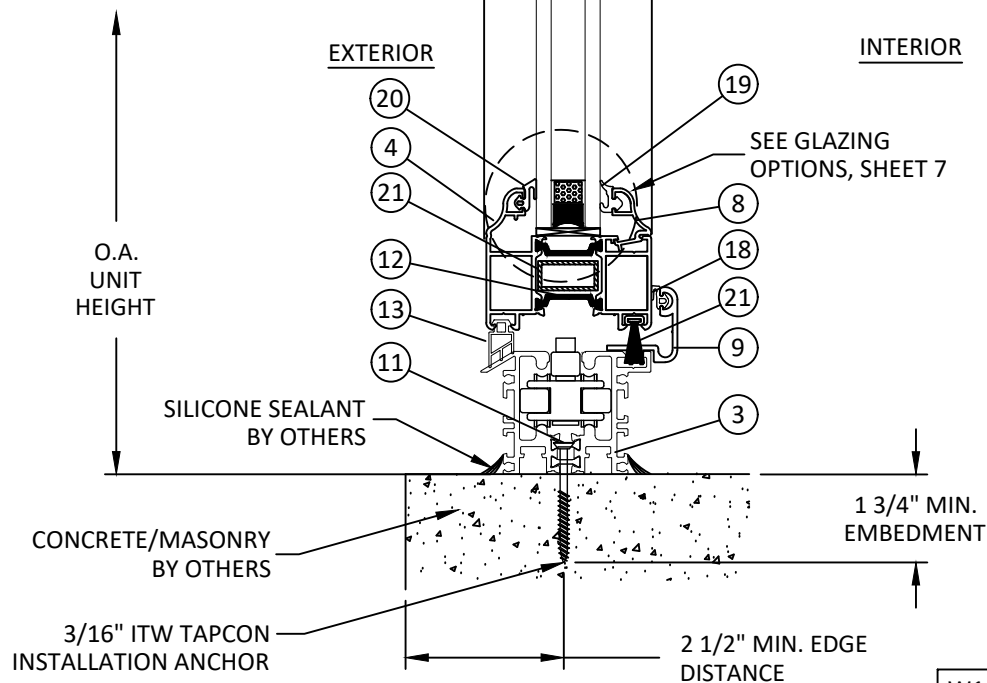

**A**  
5  
**VERTICAL SECTION**  
SILL - CONCRETE/MASONRY  
WATER BARRIER/STANDARD THRESHOLD

W1: 1/4 WEEP HOLE AT  
18" O.C. IN WATER  
BARRIER AND FLUSH  
THRESHOLD

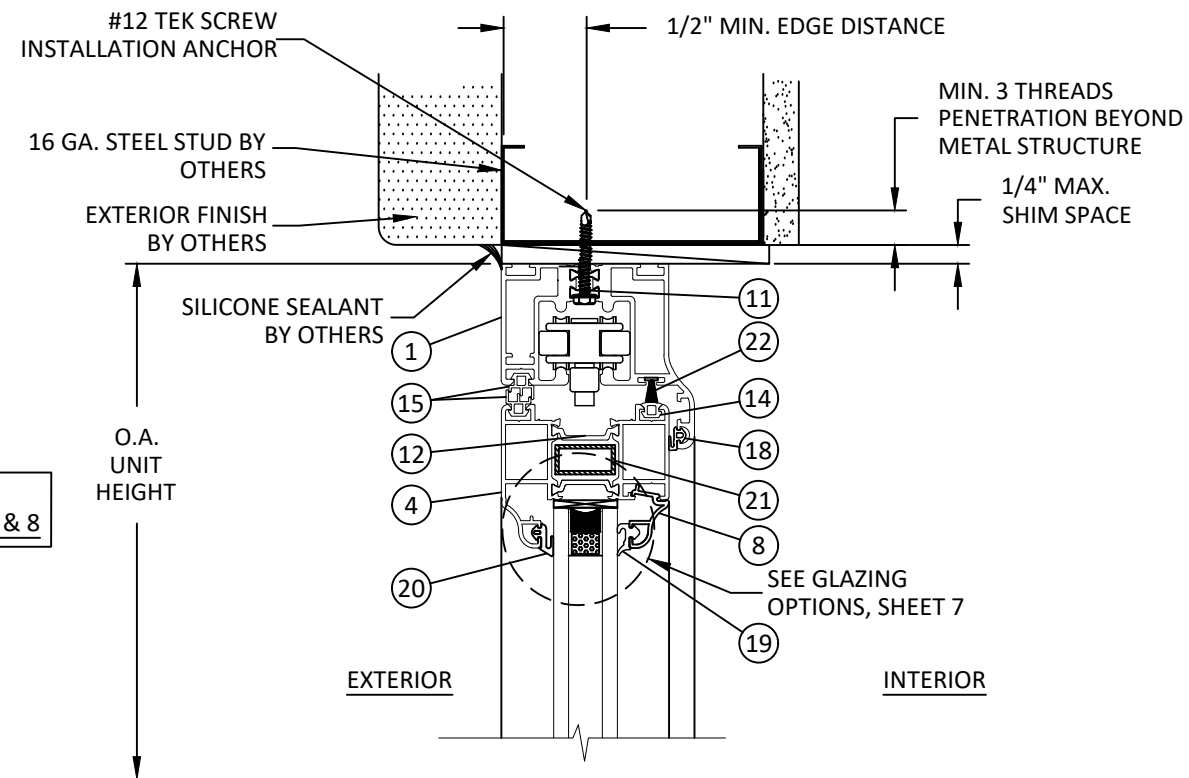

**C**  
5  
**VERTICAL SECTION**  
HEAD - STEEL STUD

MAX UNIT HEIGHT  
96-1/16"

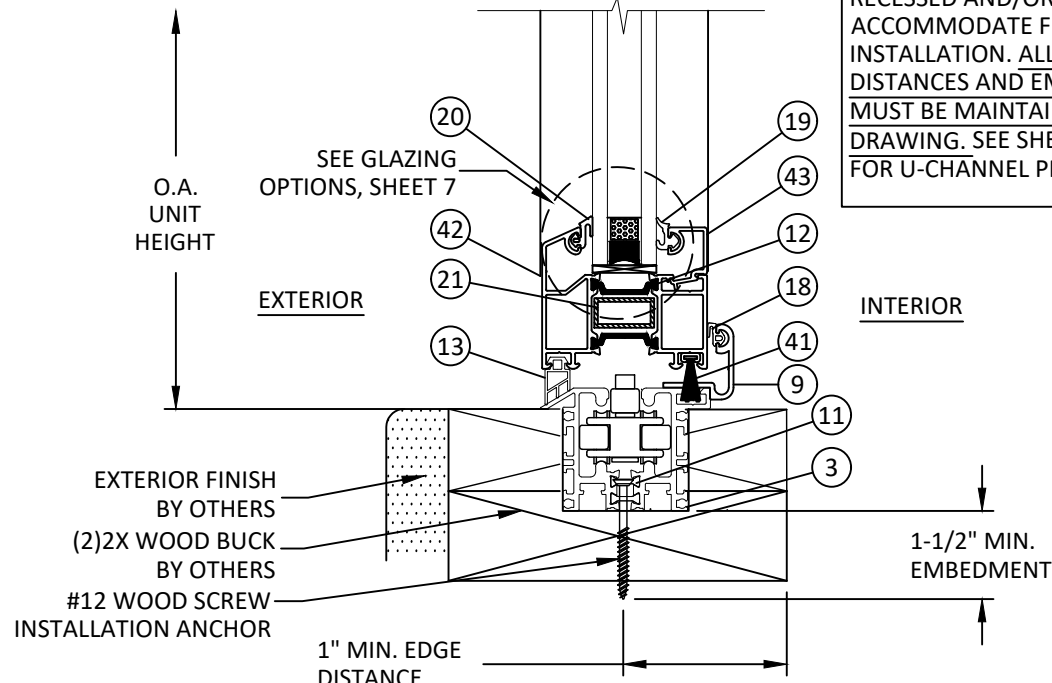

**D**  
5  
**VERTICAL SECTION**  
RECESSED U-CANNEL - 2X WOOD FRAME  
FLUSH THRESHOLD

WOOD/MASONRY/CONCRETE SHALL BE  
RECESSED AND/OR ROUTED TO  
ACCOMMODATE FLUSH THRESHOLD PRIOR TO  
INSTALLATION. ALL APPLICABLE EDGE  
DISTANCES AND EMBEDMENTS FOR ANCHORS  
MUST BE MAINTAINED AS NOTED IN THIS  
DRAWING. SEE SHEET 12, DETAILS X/12 & Y/12  
FOR U-CANNEL PREPARATION DETAILS

PARTS 42 & 43 ARE  
INTERCHANGEABLE WITH 4 & 8



THE FOLDING SLIDING  
DOOR COMPANY FSD WORKS  
HOPBINE AVE., WEST BOWLING  
BRADFORD, WEST YORKSHIRE, BD5 8ER, UK  
PH: (786) 275-5068

TITLE:  
HD82-70 MM FOLDING  
OUTFOLDING DOOR SYSTEM  
VERTICAL SECTIONS

PREPARED BY:  
BUILDING DROPS, INC.  
398 E. DANIA BEACH BLVD., STE. 338  
DANIA BEACH, FL 33004  
PH: (954)399-8478  
FAX: (954)744-4738  
WEB: www.buildingdrops.com

REMARKS	BY	DATE
5TH. ED. FBC UPDATE	SM	04.30.15
NAME & ADDRESS UPDATE	LL	07.02.19

THE INSTALLATION DETAILS DESCRIBED HEREIN ARE GENERIC  
AND MAY NOT REFLECT ACTUAL CONDITIONS FOR A SPECIFIC  
SITE. IF SITE CONDITIONS CAUSE INSTALLATION TO DEVIATE  
FROM THE REQUIREMENTS DETAILED HEREIN, A LICENSED  
ENGINEER OR ARCHITECT SHALL PREPARE SITE SPECIFIC  
DOCUMENTS FOR USE WITH THIS DOCUMENT.

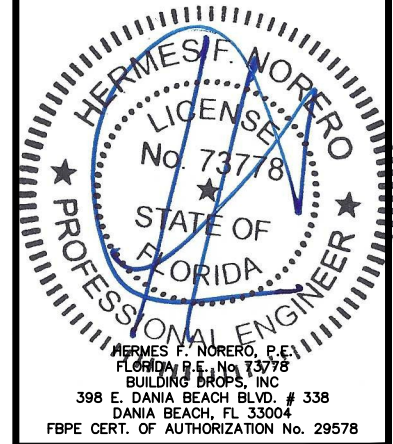

HERMES F. NORERO, P.E.  
FLORIDA P.E. No. 73778  
BUILDING DROPS, INC.  
398 E. DANIA BEACH BLVD. # 338  
DANIA BEACH, FL 33004  
FBPE CERT. OF AUTHORIZATION No. 29578

FL #:  
**FL16291**

DATE: **04.11.2013**

DWG. BY: <b>MTJ</b>	CHK. BY: <b>HFN</b>
------------------------	------------------------

SCALE: **NTS**

DWG. #: **FSD004**

SHEET:

**5**

OF 12

8/16/2019 6:00 PM

s:\projects\the folding sliding door company\fb-19-0632 - fbc submittal - name change - fl16291 aluminum folding door system\dwgs\fsd004.dwg

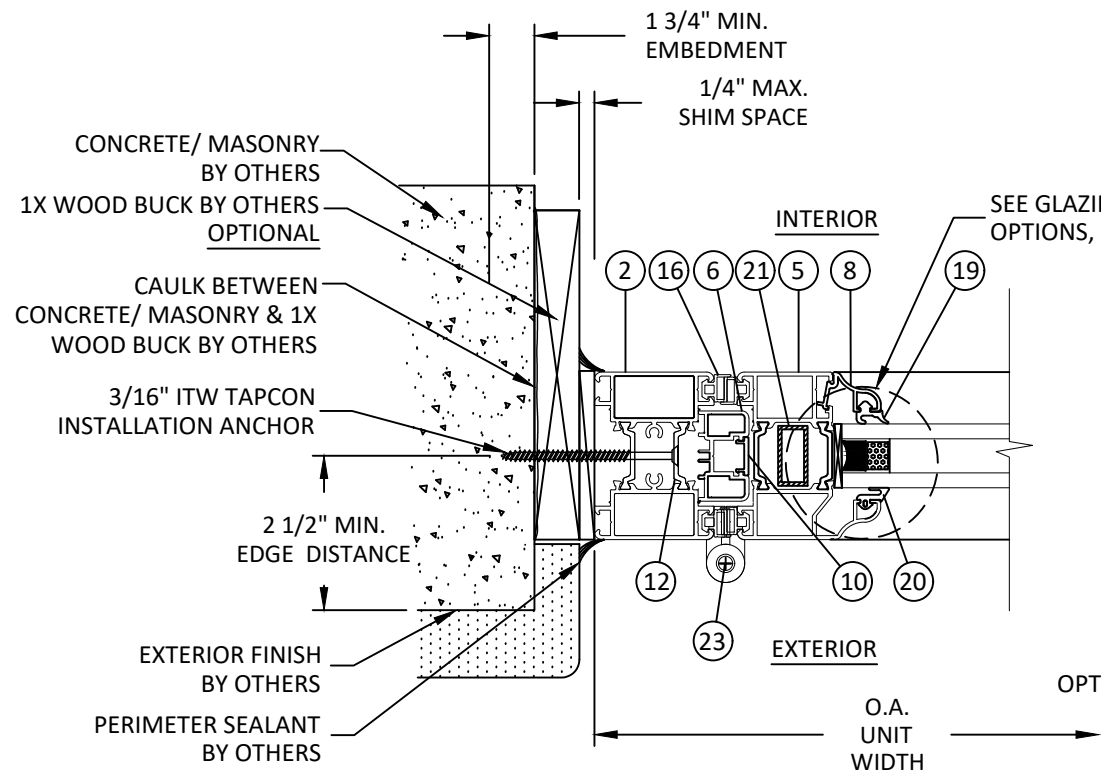

**E**  
**6** **HORIZONTAL SECTION**  
JAMB - CONCRETE/MASONRY HINGE JAMB

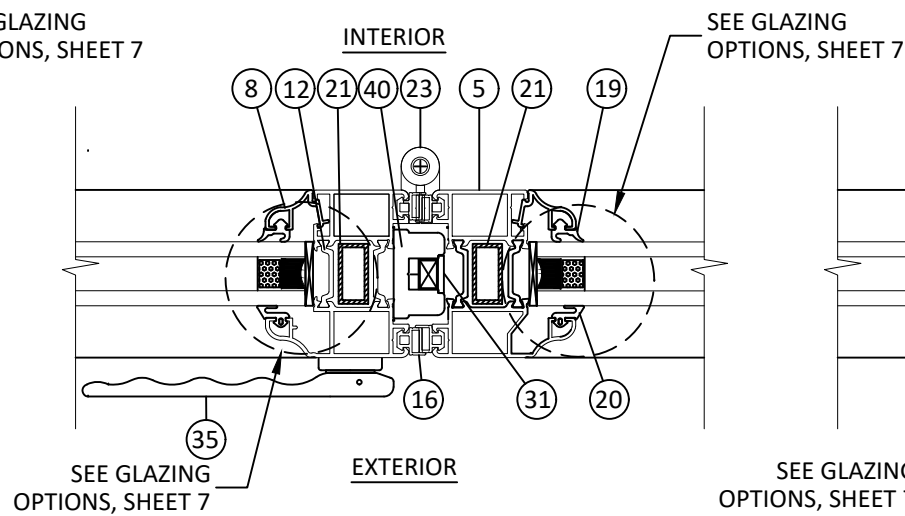

**F**  
**6** **HORIZONTAL SECTION**  
ACTIVE PANEL STILE

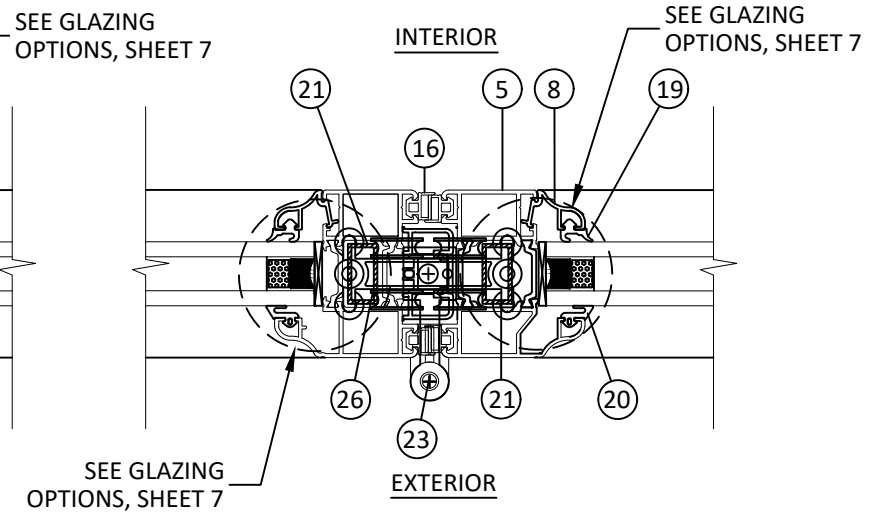

**G**  
**6** **HORIZONTAL SECTION**  
INTERMEDIATE CARRIER SET

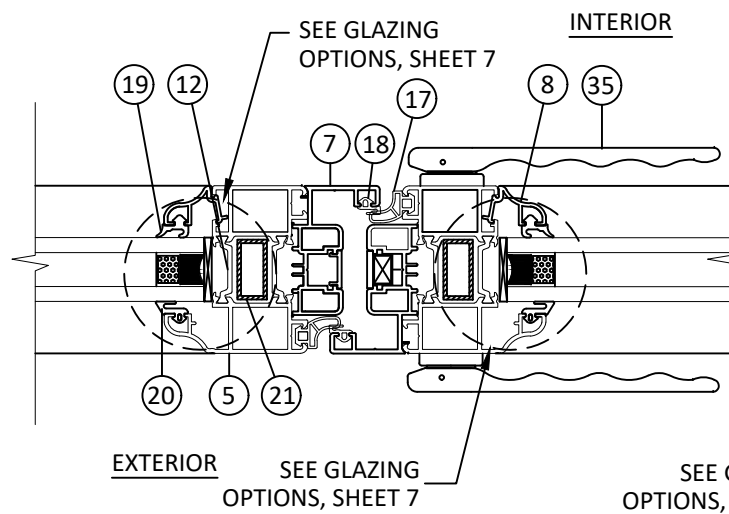

**H**  
**6** **HORIZONTAL SECTION**  
ASTRAGAL

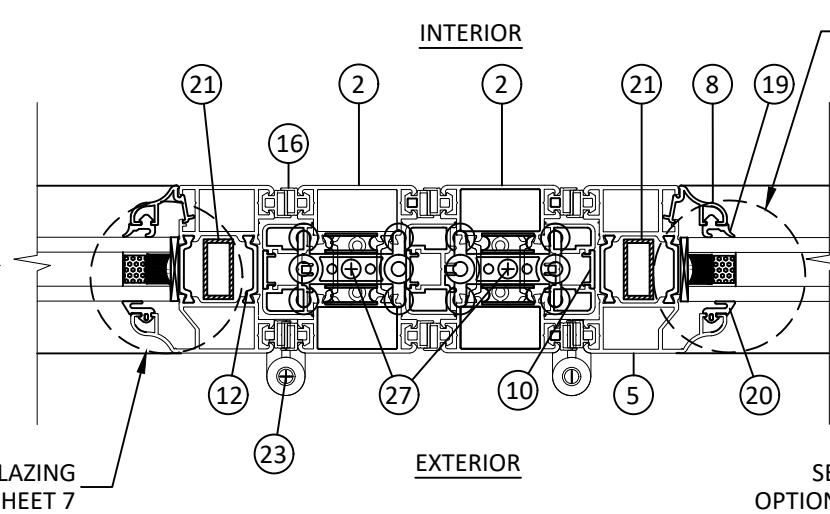

**I**  
**6** **HORIZONTAL SECTION**  
INTERMEDIATE CARRIER SET MEET

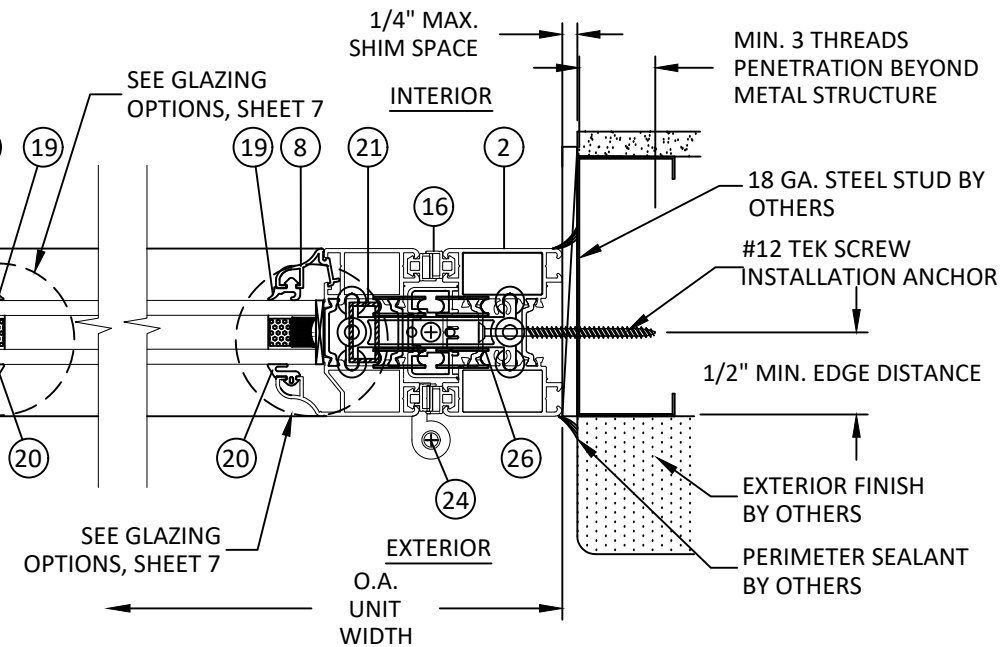

**J**  
**6** **HORIZONTAL SECTION**  
JAMB - STEEL STUD END CARRIER SET



THE FOLDING SLIDING DOOR COMPANY FSD WORKS  
HOPBINE AVE., WEST BOWLING  
BRADFORD, WEST YORKSHIRE, BD5 8ER, UK  
PH: (786) 275-5068

TITLE:  
HD82-70 MM FOLDING  
OUTFOLDING DOOR SYSTEM  
HORIZONTAL SECTIONS

PREPARED BY:  
BUILDING DROPS, INC.  
398 E. DANIA BEACH BLVD., STE. 338  
DANIA BEACH, FL 33004  
PH: (954)399-8478  
FAX: (954)744-4738  
WEB: www.buildingdrops.com

REMARKS	BY	DATE
5TH. ED. FBC UPDATE	SM	04.30.15
NAME & ADDRESS UPDATE	LL	07.02.19

THE INSTALLATION DETAILS DESCRIBED HEREIN ARE GENERIC AND MAY NOT REFLECT ACTUAL CONDITIONS FOR A SPECIFIC SITE. IF SITE CONDITIONS CAUSE INSTALLATION TO DEVIATE FROM THE REQUIREMENTS DETAILED HEREIN, A LICENSED ENGINEER OR ARCHITECT SHALL PREPARE SITE SPECIFIC DOCUMENTS FOR USE WITH THIS DOCUMENT.

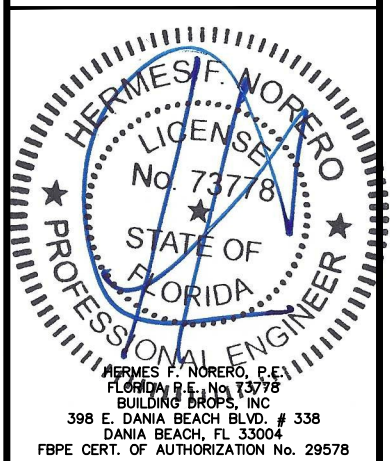

FL #:  
**FL16291**

DATE: **04.11.2013**

DWG. BY: **MTJ** | CHK. BY: **HFN**

SCALE: **NTS**

DWG. #: **FSD004**

SHEET:  
**6**

OF 12



8/16/2019 6:00 PM

s:\projects\the folding sliding door company\fb-19-0632 - fbc submittal - name change - fl16291 aluminum folding door system\dwg\fsd004.dwg

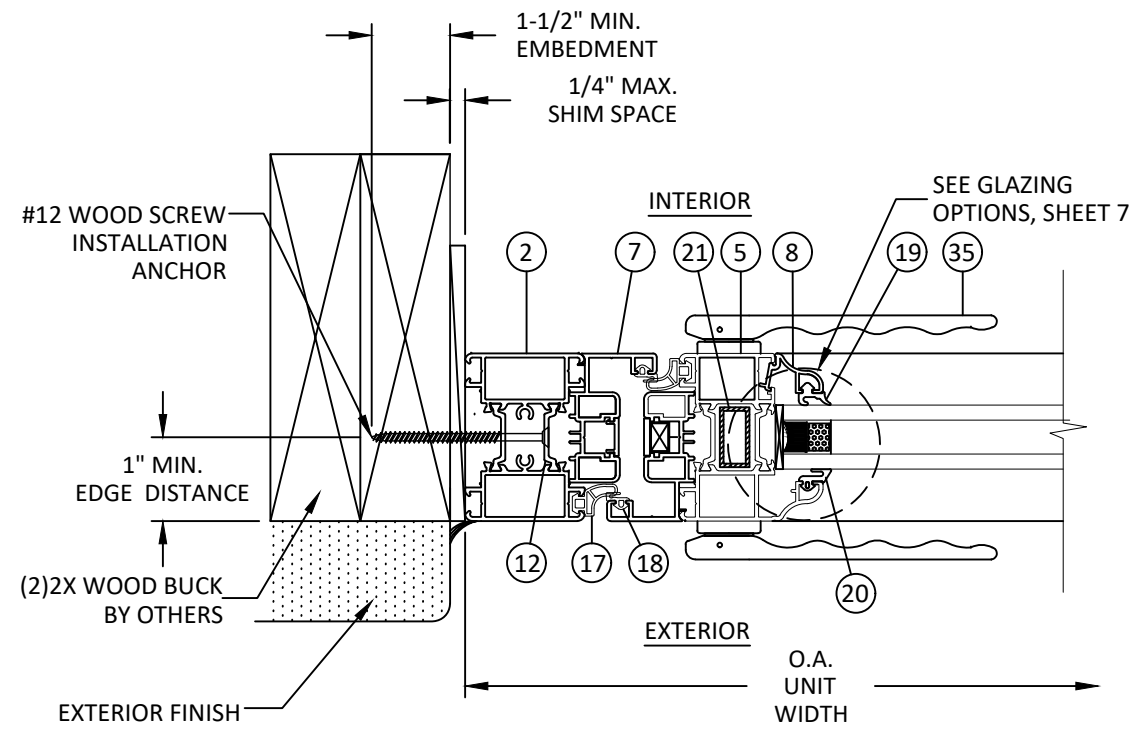

**K**  
**7**  
**HORIZONTAL SECTION**  
JAMB - 2X WOOD FRAME  
LOCKING JAMB

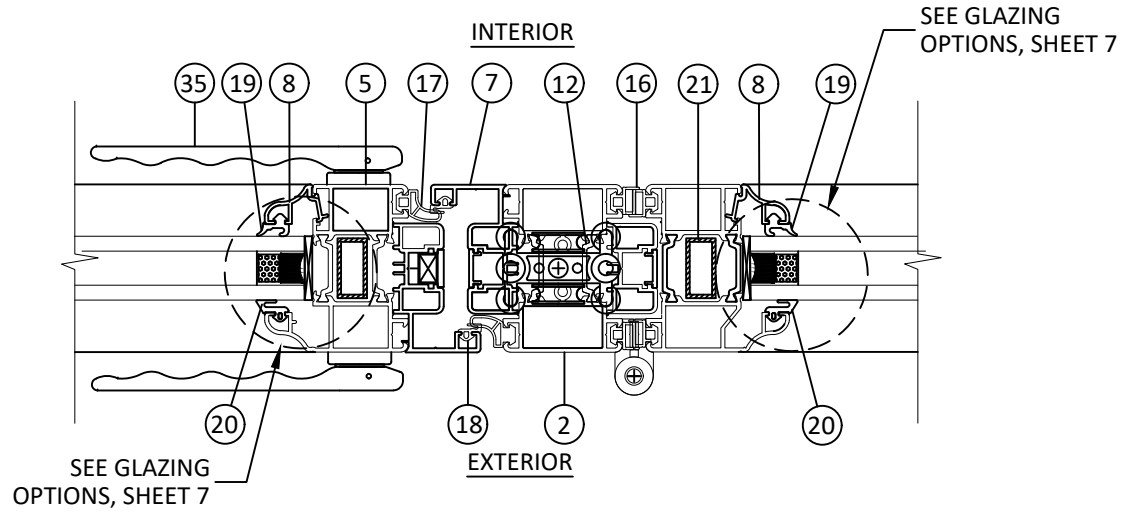

**L**  
**7**  
**HORIZONTAL SECTION**  
INTERMEDIATE LOCK AT CARRIER

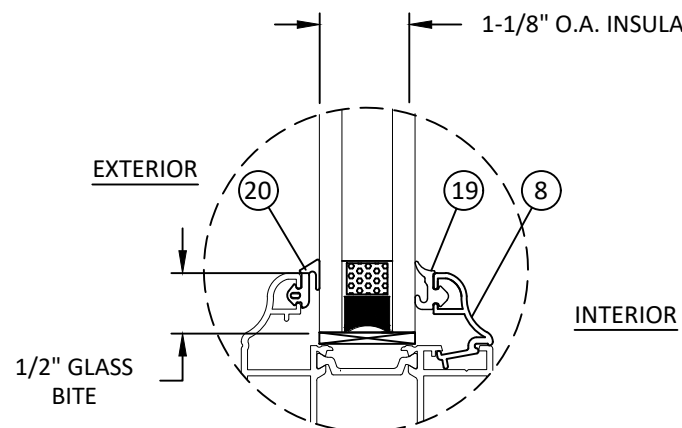

**GLAZING DETAIL 1**

**GLAZING NOTES:**

1. ALL GLAZING CONFIGURATIONS SHALL COMPLY WITH SAFETY GLAZING REQUIREMENTS OF THE FBC WITH EVIDENCE TO BE SUPPLIED TO BUILDING OFFICIAL.
2. GLASS THICKNESS AND TYPE MAY VARY PER ASTM E 1300 REQUIREMENT GLASS CHARTS.
3. GLAZING GASKETS SHALL MEET THE REQUIREMENTS OF THE FBC.
4. GLASS SHALL BE SET ON SETTING BLOCKS IN ACCORDANCE WITH FBC CH. 24 REQUIREMENTS

**The Folding Sliding Door Company**  
Jack of one trade, master of one

THE FOLDING SLIDING DOOR COMPANY FSD WORKS  
HOPBINE AVE., WEST BOWLING  
BRADFORD, WEST YORKSHIRE, BD5 8ER, UK  
PH: (786) 275-5068

TITLE: HD82-70 MM FOLDING OUTFOLDING DOOR SYSTEM HORIZONTAL SECTIONS & GLAZING DETAILS

PREPARED BY: BUILDING DROPS, INC.  
398 E. DANIA BEACH BLVD., STE. 338  
DANIA BEACH, FL 33004  
PH: (954)399-8478  
FAX: (954)744-4738  
WEB: www.buildingdrops.com

REMARKS	BY	DATE
5TH. ED. FBC UPDATE	SM	04.30.15
NAME & ADDRESS UPDATE	LL	07.02.19

THE INSTALLATION DETAILS DESCRIBED HEREIN ARE GENERIC AND MAY NOT REFLECT ACTUAL CONDITIONS FOR A SPECIFIC SITE. IF SITE CONDITIONS CAUSE INSTALLATION TO DEVIATE FROM THE REQUIREMENTS DETAILED HEREIN, A LICENSED ENGINEER OR ARCHITECT SHALL PREPARE SITE SPECIFIC DOCUMENTS FOR USE WITH THIS DOCUMENT.

HERMES F. NORERO, P.E.  
FLORIDA P.E. No. 73778  
BUILDING DROPS, INC.  
398 E. DANIA BEACH BLVD., # 338  
DANIA BEACH, FL 33004  
FBPE CERT. OF AUTHORIZATION No. 29578

FL #: **FL16291**

DATE: **04.11.2013**

DWG. BY: **MTJ**      CHK. BY: **HFN**

SCALE: **NTS**

DWG. #: **FSD004**

SHEET:

## DESIGN PRESSURE TABLE

PANEL SIZE		DESIGN PRESSURE (PSF)	
W (in.)	H (in.)	Pos.*	Neg.
20	80	140.9	140.9
	88	126.4	126.4
	96	114.7	114.7
	104	89.5	89.5
	112	71.1	71.1
	120	57.5	57.5
	128	47.1	47.1
	144	32.8	32.8
24	80	120.9	120.9
	88	108.1	108.1
	96	97.8	97.8
	104	76.2	76.2
	112	60.5	60.5
	120	48.8	48.8
	128	39.9	39.9
	144	27.7	27.7
28	80	106.7	106.7
	88	95.2	95.2
	96	85.9	85.9
	104	66.8	66.8
	112	52.9	52.9
	120	42.6	42.6
	128	34.8	34.8
32	80	96.3	96.3
	88	85.6	85.6
	96	77.0	77.0
	104	59.8	59.8
	112	47.2	47.2
	113	45.9	45.9
36	80	88.4	88.4
	88	78.3	78.3
	96	70.2	70.2
	100	61.7	61.7
40	80	82.2	82.2
	88	75.3	75.3
	90	73.2	73.2
44	80	77.3	77.3
	82	74.7	74.7
48	75	80.6	80.6

**\* NOTE:**

- UNIT RATED FOR WATER INFILTRATION UP TO 70 PSF WHEN USING WATER BARRIER THRESHOLD ONLY.
- WHERE STANDARD & FLUSH THRESHOLDS ARE USED AND WATER INFILTRATION IS REQUIRED, UNIT SHALL BE INSTALLED AT LOCATIONS PROTECTED BY OVERHANG SUCH THAT THE OVERHANG RATIO (OH) = OH LENGTH/OH HEIGHT GREATER THAN 1.0



THE FOLDING SLIDING  
DOOR COMPANY FSD WORKS  
HOPBINE AVE., WEST BOWLING  
BRADFORD, WEST YORKSHIRE, BD5 8ER, UK  
PH: (786) 275-5068

TITLE:  
HD82-70 MM FOLDING  
OUTFOLDING DOOR SYSTEM  
DESIGN PRESSURE TABLES

PREPARED BY:  
**BUILDING DROPS, INC.**  
398 E. DANIA BEACH BLVD., STE. 338  
DANIA BEACH, FL 33004  
PH: (954)399-8478  
FAX: (954)744-4738  
WEB: www.buildingdrops.com



REMARKS	BY	DATE
5TH. ED. FBC UPDATE	SM	04.30.15
NAME & ADDRESS UPDATE	LL	07.02.19

THE INSTALLATION DETAILS DESCRIBED HEREIN ARE GENERIC AND MAY NOT REFLECT ACTUAL CONDITIONS FOR A SPECIFIC SITE. IF SITE CONDITIONS CAUSE INSTALLATION TO DEVIATE FROM THE REQUIREMENTS DETAILED HEREIN, A LICENSED ENGINEER OR ARCHITECT SHALL PREPARE SITE SPECIFIC DOCUMENTS FOR USE WITH THIS DOCUMENT.

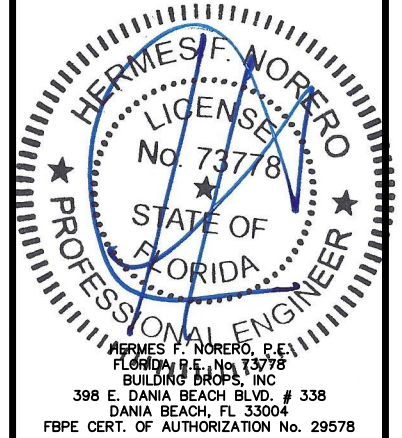

FL #:	<b>FL16291</b>
DATE:	<b>04.11.2013</b>
DWG. BY:	<b>MTJ</b>
CHK. BY:	<b>HFN</b>
SCALE:	<b>NTS</b>
DWG. #:	<b>FSD004</b>
SHEET:	<b>8</b>



8/16/2019 6:01 PM

s:\projects\the folding sliding door company\fb-19-0632 - fb-16291 - aluminum folding door system\dwgs\fsd004.dwg

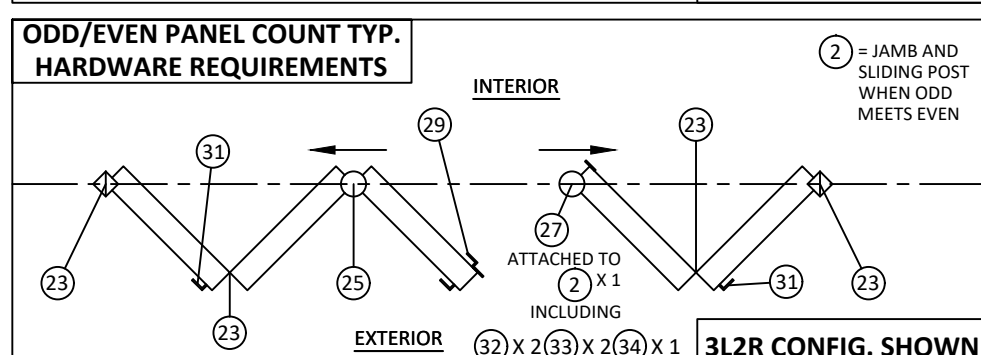
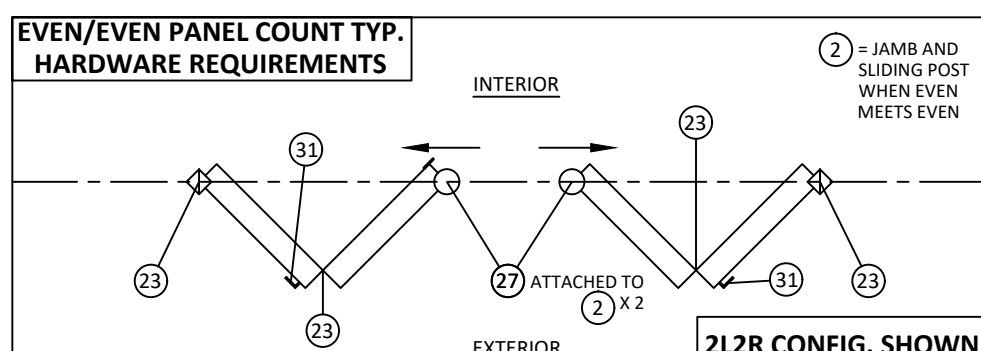
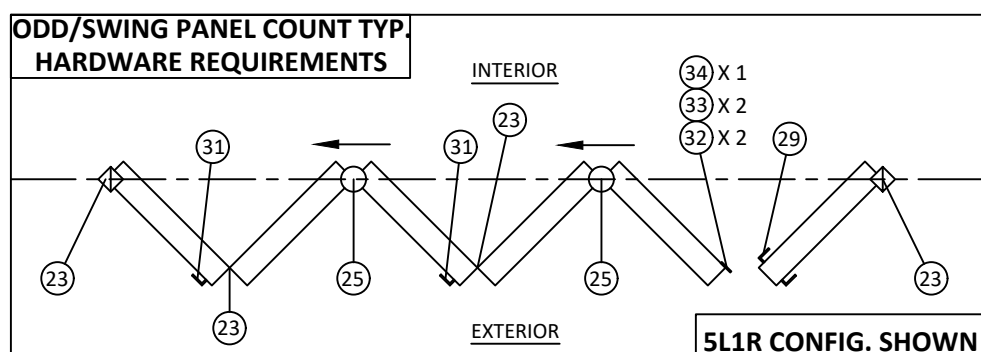
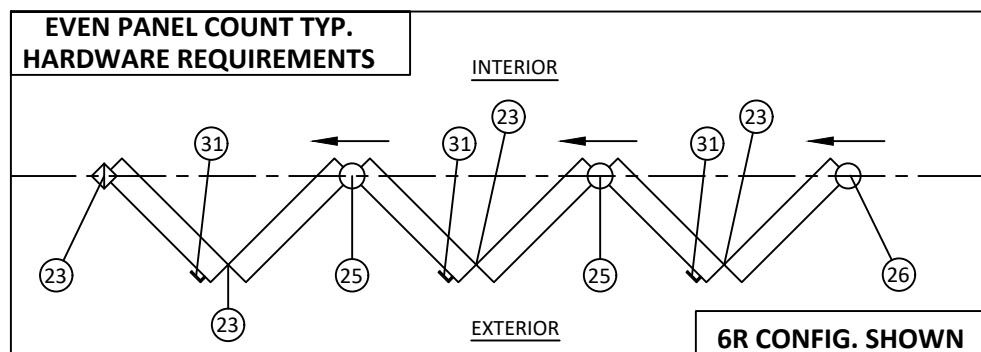
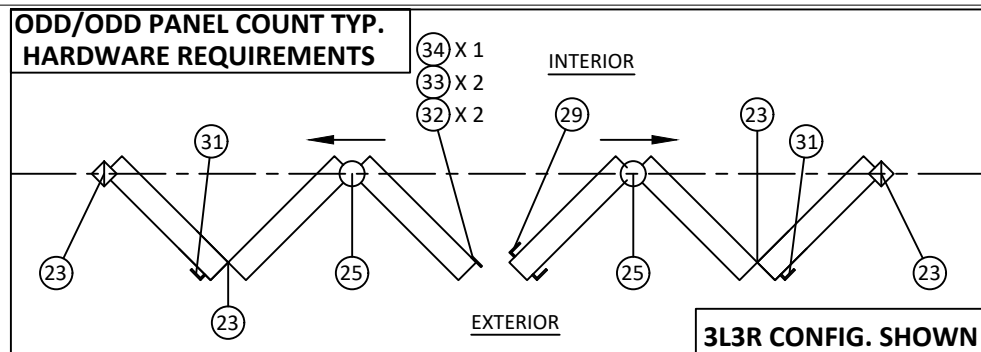

- NOTES:
- MAXIMUM PANEL SIZE: SEE SHEET 8 FOR SIZES.
  - TERMINAL PANEL HARDWARE:
    - 'ODD' TO 'ODD' PANEL COUNT (I.E. 3L3R CONFIG.)- REQUIRES 5-PT LOCK (ITEM 29) ON ACTIVE SWING PANEL.
    - 'ODD' TO 'EVEN' PANEL COUNT (I.E. 3L2R CONFIG.)- REQUIRES 5-PT LOCK (ITEM 29) ON ACTIVE SWING PANEL AND ONE END CARRIER SET (ITEM 27) ON CARRIER JOINT PANEL.
    - 'EVEN' TO 'EVEN' PANEL COUNT (I.E. 2L4R CONFIG.) - REQUIRES ONE END CARRIER SET (ITEM 27) ON BOTH CARRIER JOINT PANELS.
    - 'ODD' PANEL COUNT INTO JAMB (I.E. 5L CONFIG.) - REQUIRES 5-PT LOCK (ITEM 29) ON ACTIVE SWING PANEL
    - 'EVEN' PANEL INTO JAMB (I.E. 6L) - REQUIRES ONE END CARRIER SET (ITEM 26)
  - HINGED JOINT PANELS - ALL HINGED PANELS REQUIRE FIVE CENTER HINGES (ITEM 23 OR 24) AND 2-PT LOCK (ITEM 31)
  - CARRIER JOINT PANELS - ALL CARRIER PANELS REQUIRE AN INTERMEDIATE CARRIER SET (ITEM 25), AND FIVE HINGES (ITEM 23)

PANEL CT.	QUALIFIED CONFIGURATIONS									
1	1L	1R	-	-	-	-	-	-	-	-
2	1L1R	2L	2R	-	-	-	-	-	-	-
3	1L2R	2L1R	3L	3R	-	-	-	-	-	-
4	1L3R	3L1R	2L2R	4L	4R	-	-	-	-	-
5	1L4R	4L1R	2L3R	3L2R	5L	5R	-	-	-	-
6	1L5R	5R1L	2L4R	4R2L	3L3R	6L	6R	-	-	-
7	1L6R	6L1R	2L5R	5L2R	3L4R	4R3L	7L	7R	-	-
8	1L7R	7L1R	2L6R	6L2R	3L5R	5L3R	4L4R	8L	8R	-
9	1L8R	8L1R	2L7R	7L2R	3L6R	6R3L	4L5R	5L4R	-	-
10	2L8R	8L2R	3L7R	7L3R	4L6R	6L4R	5L5R	-	-	-
11	3L8R	8L3R	4L7R	7L4R	5L6R	6L5R	-	-	-	-
12	4L8R	8L4R	5L7R	7L5R	6L6R	-	-	-	-	-
13	5L8R	8L5R	6L7R	7L6R	-	-	-	-	-	-
14	6L8R	8L6R	7L7R	-	-	-	-	-	-	-
15	7L8R	8L7R	-	-	-	-	-	-	-	-
16	8L8R	-	-	-	-	-	-	-	-	-

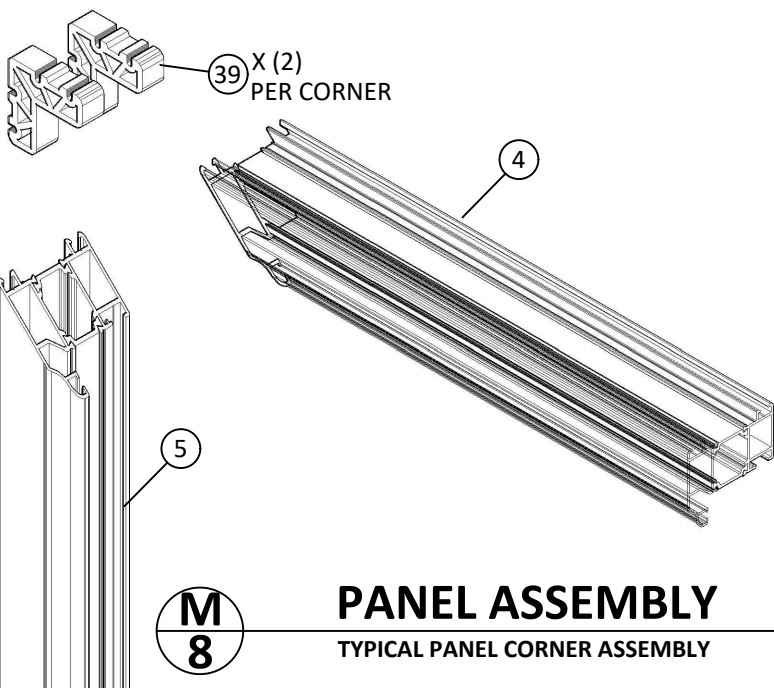

NOTE: FRAME CORNER ASSEMBLY IS SIMILAR USING (2) FRAME CORNER KEYS (38)



HDB82-70 MM FOLDING  
OUTFOLDING DOOR SYSTEM,  
HARDWARE REQUIREMENTS,  
CONFIGURATIONS &  
DESIGN PRESSURE TABLES

PREPARED BY:  
**BUILDING DROPS, INC.**  
398 E. DANIA BEACH BLVD., STE. 338  
DANIA BEACH, FL 33004  
PH: (954)399-8478  
FAX: (954)744-4738  
WEB: www.buildingdrops.com

REMARKS	BY	DATE
5TH. ED. FBC UPDATE	SM	04.30.15
NAME & ADDRESS UPDATE	LL	07.02.19

THE INSTALLATION DETAILS DESCRIBED HEREIN ARE GENERIC AND MAY NOT REFLECT ACTUAL CONDITIONS FOR A SPECIFIC SITE. IF SITE CONDITIONS CAUSE INSTALLATION TO DEVIATE FROM THE REQUIREMENTS DETAILED HEREIN, A LICENSED ENGINEER OR ARCHITECT SHALL PREPARE SITE SPECIFIC DOCUMENTS FOR USE WITH THIS DOCUMENT.

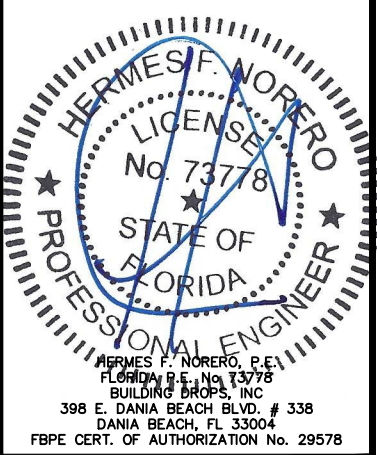

FL #:  
**FL16291**

DATE: **04.11.2013**

DWG. BY: **MTJ** | CHK. BY: **HFN**

SCALE: **NTS**

DWG. #: **FSD004**

SHEET:  
**9**  
OF 12

8/16/2019 6:01 PM

s:\projects\the folding sliding door company\lbc-19-0632 - fbc submittal - name change - fl16291 aluminum folding door system\dwg\fsd04.dwg

### BILL OF MATERIALS

ITEM NO.	DESCRIPTION	PART NO.	MATERIAL	MANUFACTURER
1	FRAME HEAD (WITH ITEM 11)	8202	AL. 6063-T5	FSD CO.
2	FRAME JAMB/STILE (WITH ITEM 12)	8203	AL. 6063-T5	FSD CO.
3	FRAME THRESHOLD (WITH ITEM 11)	8001	AL. 6063-T5	FSD CO.
4	PANEL RAIL (WITH ITEM 12)	8201	AL. 6063-T5	FSD CO.
5	PANEL STILE (WITH ITEM 12)	8201	AL. 6063-T5	FSD CO.
6	ACTIVE STILE ADAPTOR	8211	AL. 6063-T5	FSD CO.
7	ASTRAGAL ADAPTOR	8210	AL. 6063-T5	FSD CO.
8	GLAZING BEAD	8208	AL. 6063-T5	FSD CO.
9	THRESHOLD ADAPTOR	7003	AL. 6063-T5	FSD CO.
10	DUST COVER	G1194	PLASTIC	FSD CO.
11	SMALL THERMAL STRUT	---	POLYAMIDE	TECHNOFORM
12	LARGE THERMAL STRUT	---	POLYAMIDE	TECHNOFORM
13	BOTTOM RAIL GASKET	HD82BPG	EPDM	EXTRUDASEAL LTD
14	TOP RAIL GASKET	FSDBTG	EPDM	EXTRUDASEAL LTD
15	HEAD GASKET	HD82TPG	EPDM	EXTRUDASEAL LTD
16	STILE GASKET	HD82PGW	EPDM	EXTRUDASEAL LTD
17	ASTRAGAL SEAL	HD82FG	EPDM	EXTRUDASEAL LTD
18	COMPRESSION SEAL	F135	EPDM	EXTRUDASEAL LTD
19	INT. GLAZING GASKET	E732	EPDM	PERFORMANCE ELASTOMER
20	EXT. GLAZING GASKET	E732	EPDM	PERFORMANCE ELASTOMER
21	REINFORCEMENT (STILES)	---	AL. 6063-T5	FSD CO.
22	TOP PILE	FS75BS	NYLON BRUSH	FSD CO.
23	CENTER HINGE	FSH5	AL. 6063-T5	FSD CO.
24	OFFSET HINGE	FSHH	AL. 6063-T5	FSD CO.
25	INT. CARRIER SET	FS70RAHD	AL. 6063-T5	FSD CO.
26	END CARRIER SET	FS70RAHHD	ALUM./S.S.	FSD CO.
27	SNGLE CARRIER SET	FS70PRSW	ALUM./S.S.	FSD CO.
28	INTERNAL SHOOT BOLT (TOP)	FSRAB250	S.S./ZINC	FSD CO.
29	5-PT LATCH W/ DEADBOLT	FS5PL	STEEL	GU
30	INTERNAL SHOOT BOLT (BOTTOM)	FSNASB250	STEEL	FSD CO.
31	BI-FOLD 2-PT LOCK	FS2PL	STEEL	GU
32	FINGERBOLT	FSSB2/4/600	STEEL	FSD CO.
33	HOOK KEEP	FSHK	STEEL	GU
34	CENTER KEEP	FSCKL/R	STEEL	GU

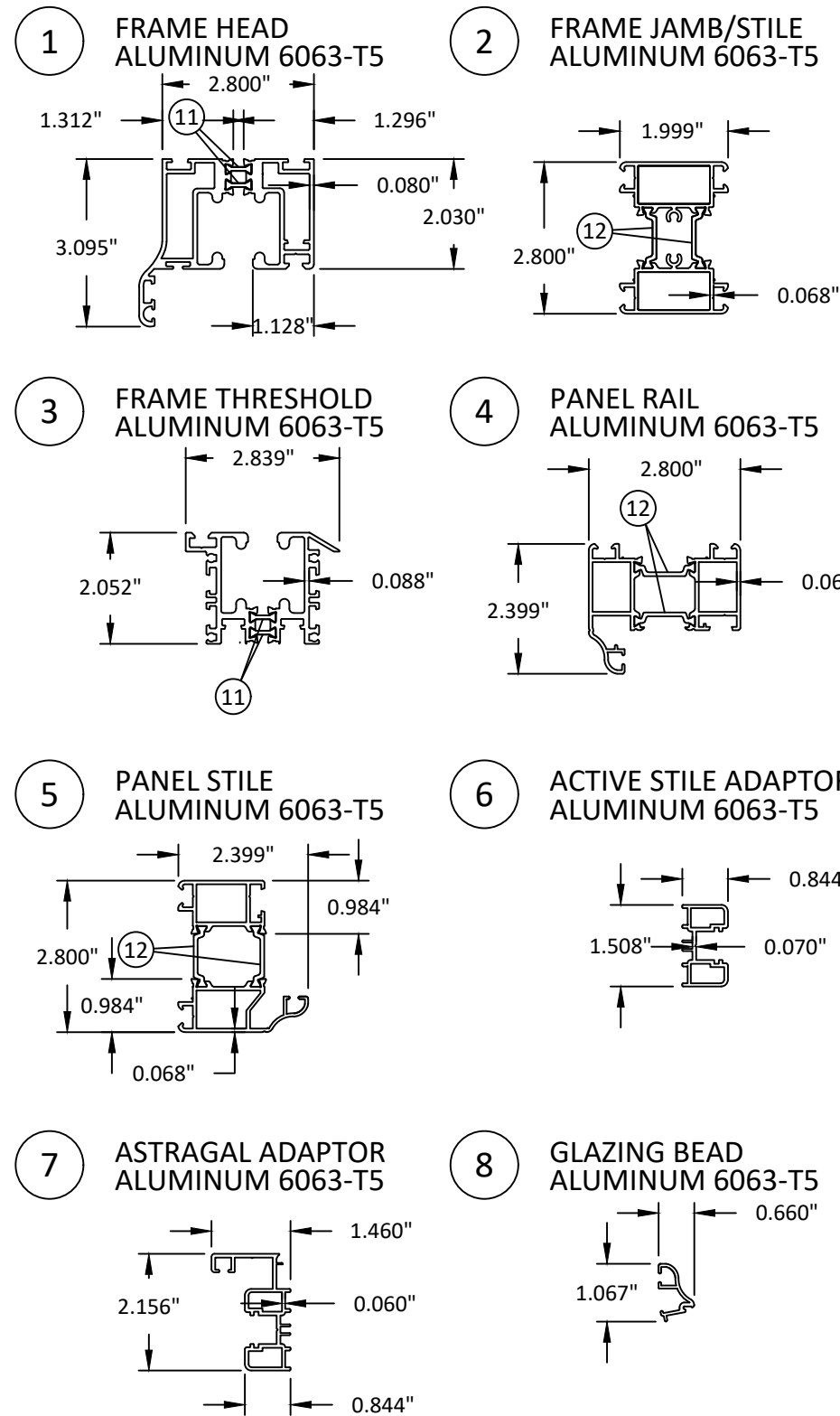

NOTE: ITEMS #23 THROUGH #27 AND ITEMS #35 THROUGH #37, MAY BE CONSTRUCTED ALTERNATIVELY, FROM GRADE 316 STAINLESS STEEL.



THE FOLDING SLIDING DOOR COMPANY FSD WORKS  
HOPBINE AVE., WEST BOWLING  
BRADFORD, WEST YORKSHIRE, BD5 8ER, UK  
PH: (786) 275-5068

TITLE: HD82-70 MM FOLDING OUTFOLDING DOOR SYSTEM COMPONENTS & BILL OF MATERIALS (1)

PREPARED BY: BUILDING DROPS, INC.  
398 E. DANIA BEACH BLVD., STE. 338  
DANIA BEACH, FL 33004  
PH: (954)399-8478  
FAX: (954)744-4738  
WEB: www.buildingdrops.com

REMARKS	BY	DATE
5TH. ED. FBC UPDATE	SM	04.30.15
NAME & ADDRESS UPDATE	LL	07.02.19

THE INSTALLATION DETAILS DESCRIBED HEREIN ARE GENERIC AND MAY NOT REFLECT ACTUAL CONDITIONS FOR A SPECIFIC SITE. IF SITE CONDITIONS CAUSE INSTALLATION TO DEVIATE FROM THE REQUIREMENTS DETAILED HEREIN, A LICENSED ENGINEER OR ARCHITECT SHALL PREPARE SITE SPECIFIC DOCUMENTS FOR USE WITH THIS DOCUMENT.

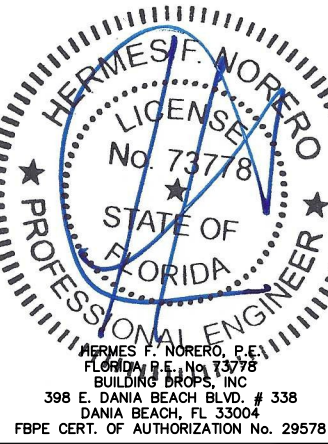

FL #: **FL16291**

DATE: **04.11.2013**

DWG. BY: **MTJ** | CHK. BY: **HFN**

SCALE: **NTS**

DWG. #: **FSD004**

SHEET: **10** OF 12

## BILL OF MATERIALS

ITEM NO.	DESCRIPTION	PART NO.	MATERIAL	MANUFACTURER
35	LEVER HANDLE	FSLL	ALUMINUM	FSD CO.
36	HALF CYLINDER	FSHC	BRASS/STEEL	FSD CO.
37	FULL CYLINDER	FSFC	BRASS/STEEL	FSD CO.
38	FRAME CORNER KEY	---	ALUMINUM	FSD CO.
39	PANEL CORNER KEY	---	ALUMINUM	FSD CO.
40	SOLID TONGUE	8211S	ALUMINUM	FSD CO.
41	BOTTOM PILE	FS75BS	NYLON BRUSH	FSD CO.
42	PANEL RAIL (WITH ITEM 12)	7201HD	AL. 6063-T5	FSD CO.
43	GLAZING BEAD	7208HD	AL. 6063-T5	FSD CO.

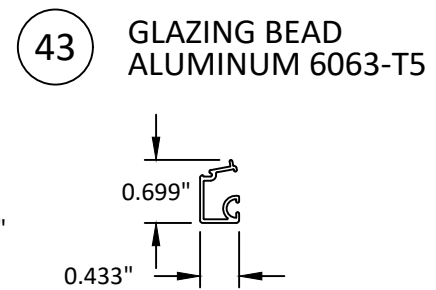
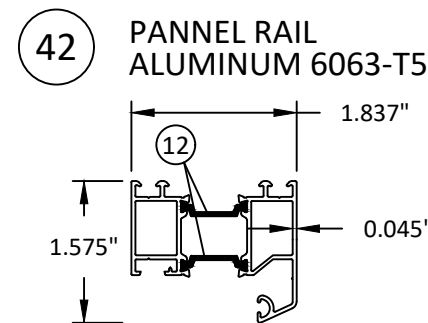
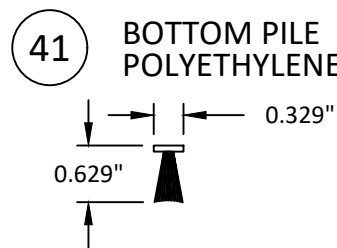
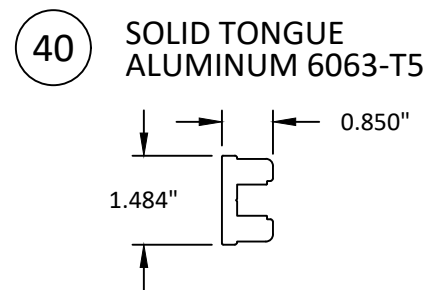
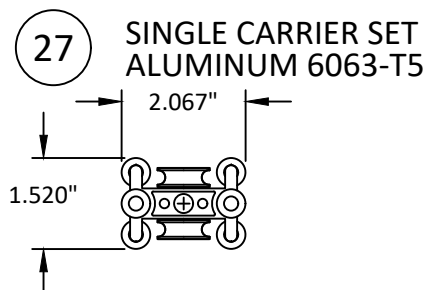
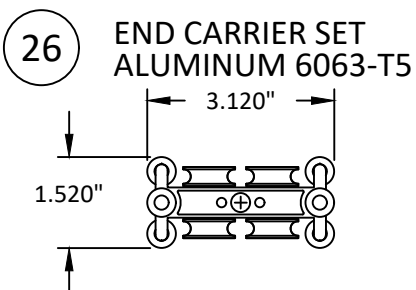
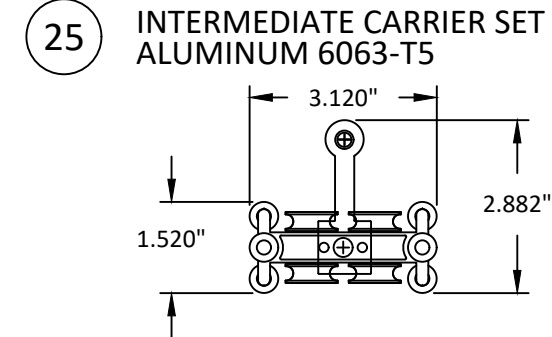
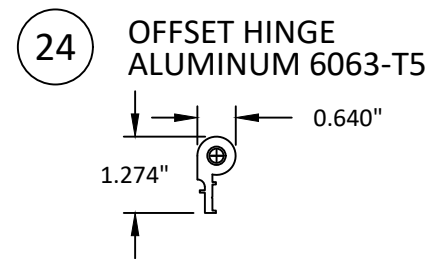
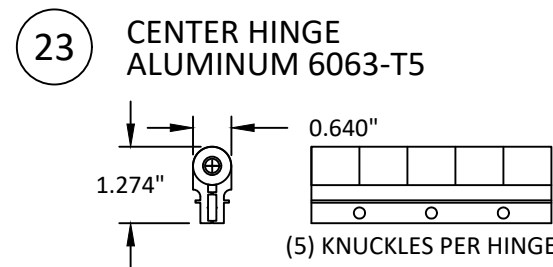
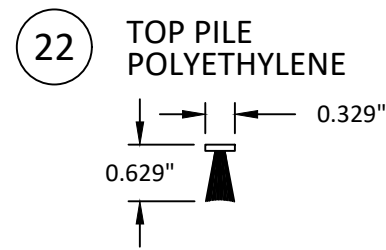
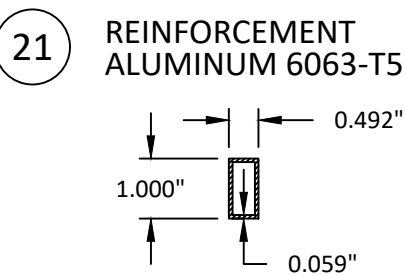
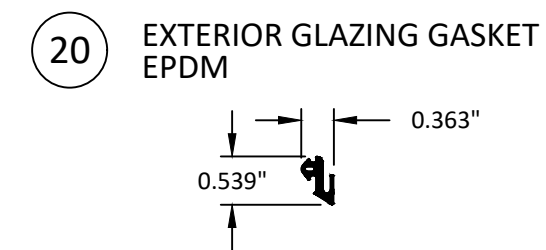
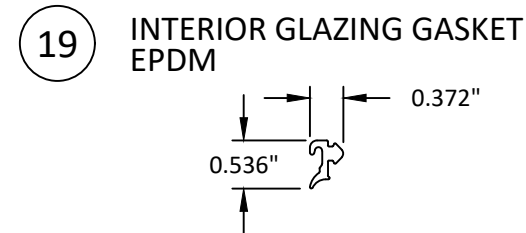
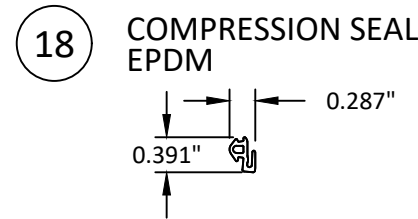
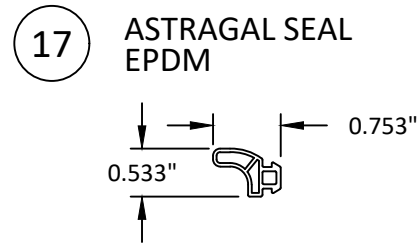
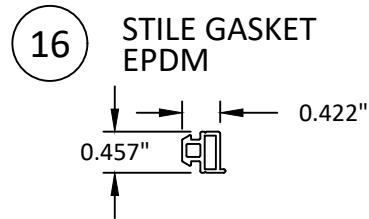
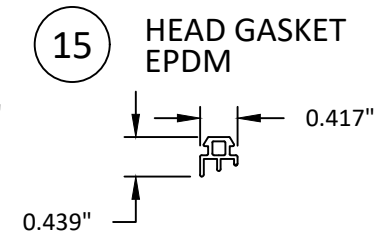
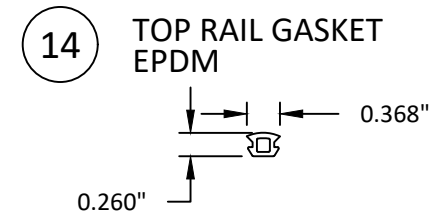
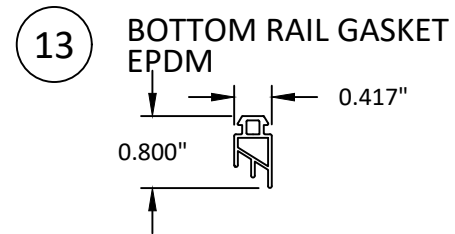
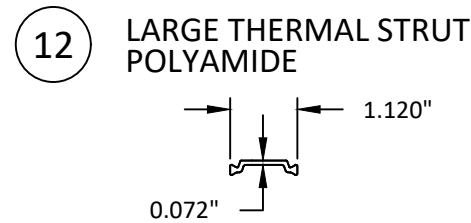
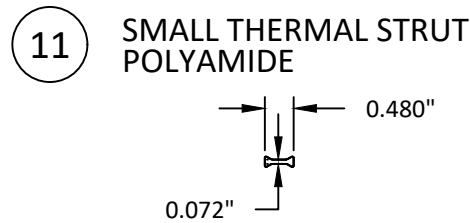
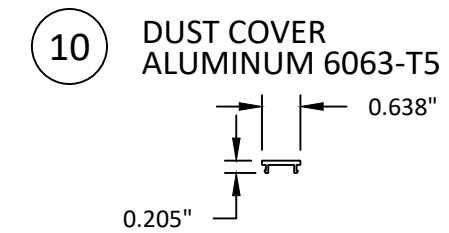
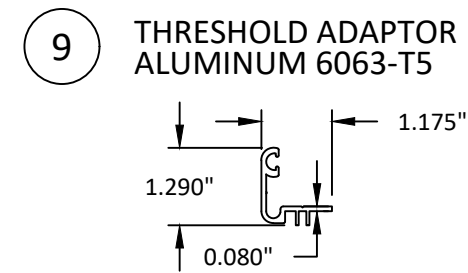

TITLE:  
HD82-70 MM FOLDING  
OUTFOLDING DOOR SYSTEM  
COMPONENTS  
& BILL OF MATERIALS (2)

PREPARED BY:  
**BUILDING DROPS, INC.**  
398 E. DANIA BEACH BLVD., STE. 338  
DANIA BEACH, FL 33004  
PH: (954)399-8478  
FAX: (954)744-4738  
WEB: www.buildingdrops.com

REMARKS	BY	DATE
5TH. ED. FBC UPDATE	SM	04.30.15
NAME & ADDRESS UPDATE	LL	07.02.19

THE INSTALLATION DETAILS DESCRIBED HEREIN ARE GENERIC AND MAY NOT REFLECT ACTUAL CONDITIONS FOR A SPECIFIC SITE. IF SITE CONDITIONS CAUSE INSTALLATION TO DEVIATE FROM THE REQUIREMENTS DETAILED HEREIN, A LICENSED ENGINEER OR ARCHITECT SHALL PREPARE SITE SPECIFIC DOCUMENTS FOR USE WITH THIS DOCUMENT.

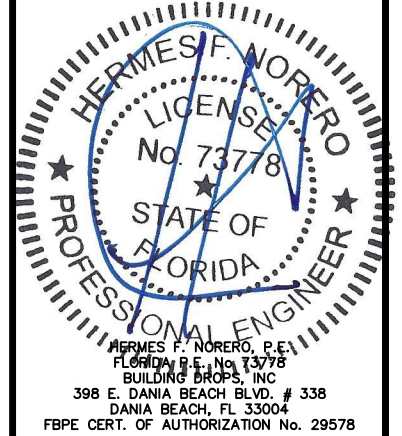

FL #:  
**FL16291**

DATE: **04.11.2013**

DWG. BY: **MTJ** | CHK. BY: **HFN**

SCALE: **NTS**

DWG. #: **FSD004**

SHEET:  
**11**

OF 12



8/16/2019 6:01 PM

s:\projects\the folding sliding door company\bc-19-0632 - fbc submittal - name change - fl16291 aluminum folding door system\dwg\fsd004.dwg

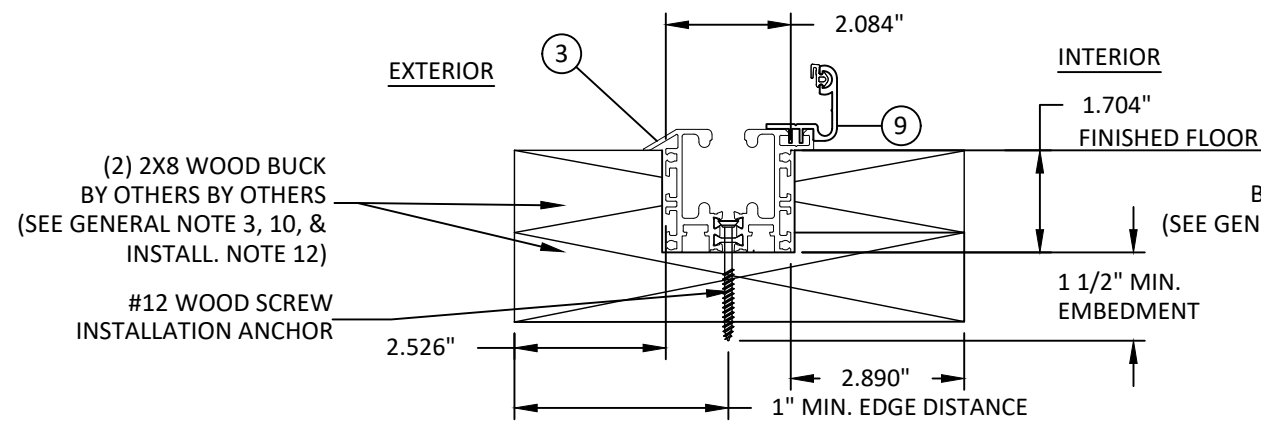

**X**  
**12** RECESSED U-CHANNEL  
2X8 WOOD BUCK INSTALLATION PREPARATION

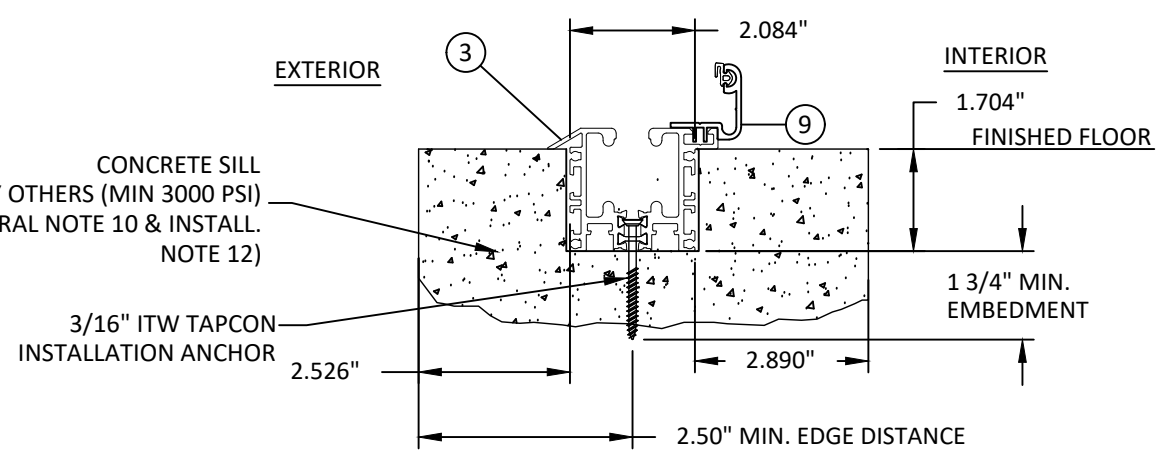

**Y**  
**12** RECESSED U-CHANNEL  
CONCRETE INSTALLATION PREPARATION

ALL SUBSTRATES MUST BE RECESSED AND/OR ROUTED TO ACCOMMODATE THESE COMPONENTS PRIOR TO INSTALLATION. ALL EDGE DISTANCES AND EMBEDMENTS FOR ANCHORS MUST BE MAINTAINED AS NOTED IN THIS SHEET.

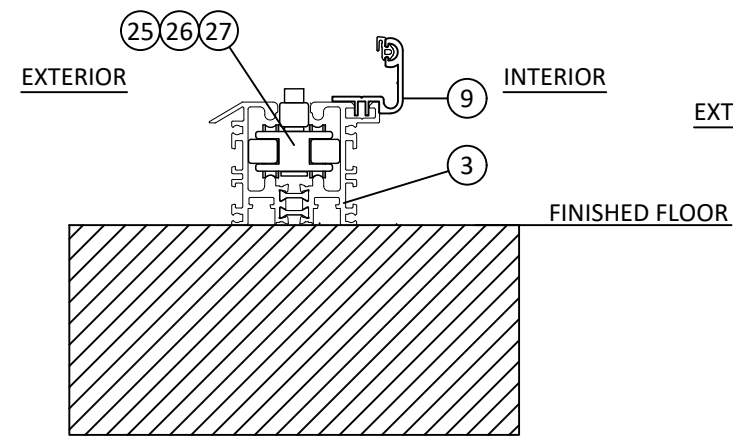

**WATER BARRIER THRESHOLD**  
(SEE INSTALLATION DETAIL A/5)

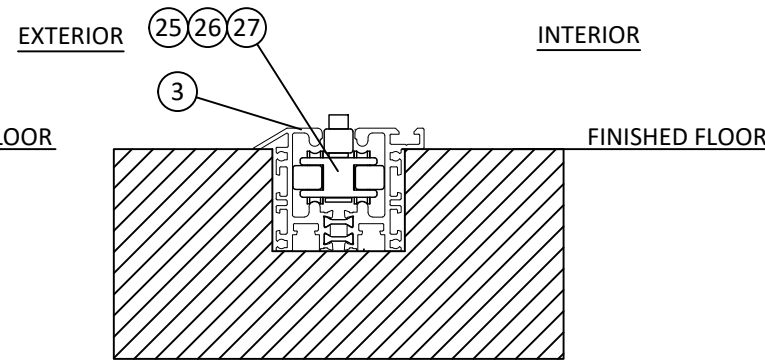

**FLUSH THRESHOLD**  
(SEE INSTALLATION DETAILS X/11 & Y/11 ABOVE)



THE FOLDING SLIDING DOOR COMPANY FSD WORKS  
HOPBINE AVE., WEST BOWLING  
BRADFORD, WEST YORKSHIRE, BD5 8ER, UK  
PH: (786) 275-5068

TITLE: HD82-70 MM FOLDING  
OUTFOLDING DOOR SYSTEM  
INSTALLATION  
PREPARATION DETAILS

PREPARED BY: BUILDING DROPS, INC.  
398 E. DANIA BEACH BLVD., STE. 338  
DANIA BEACH, FL 33004  
PH: (954) 399-8478  
FAX: (954) 744-4738  
WEB: www.buildingdrops.com

REMARKS	BY	DATE
5TH. ED. FBC UPDATE	SM	04.30.15
NAME & ADDRESS UPDATE	LL	07.02.19

THE INSTALLATION DETAILS DESCRIBED HEREIN ARE GENERIC AND MAY NOT REFLECT ACTUAL CONDITIONS FOR A SPECIFIC SITE. IF SITE CONDITIONS CAUSE INSTALLATION TO DEVIATE FROM THE REQUIREMENTS DETAILED HEREIN, A LICENSED ENGINEER OR ARCHITECT SHALL PREPARE SITE SPECIFIC DOCUMENTS FOR USE WITH THIS DOCUMENT.

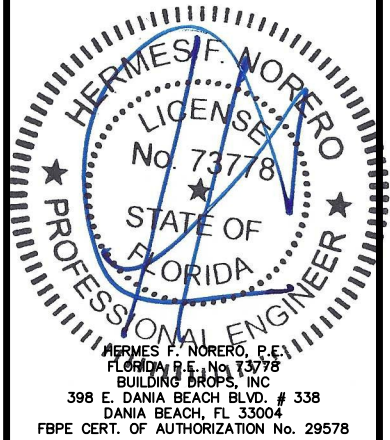

FL #: **FL16291**

DATE: **04.11.2013**

DWG. BY: **MTJ** | CHK. BY: **HFN**

SCALE: **NTS**

DWG. #: **FSD004**

SHEET: **12**

OF 12